

*Please Keep For Future Reference Only.

KONA SERIES ASSEMBLY INSTRUCTION

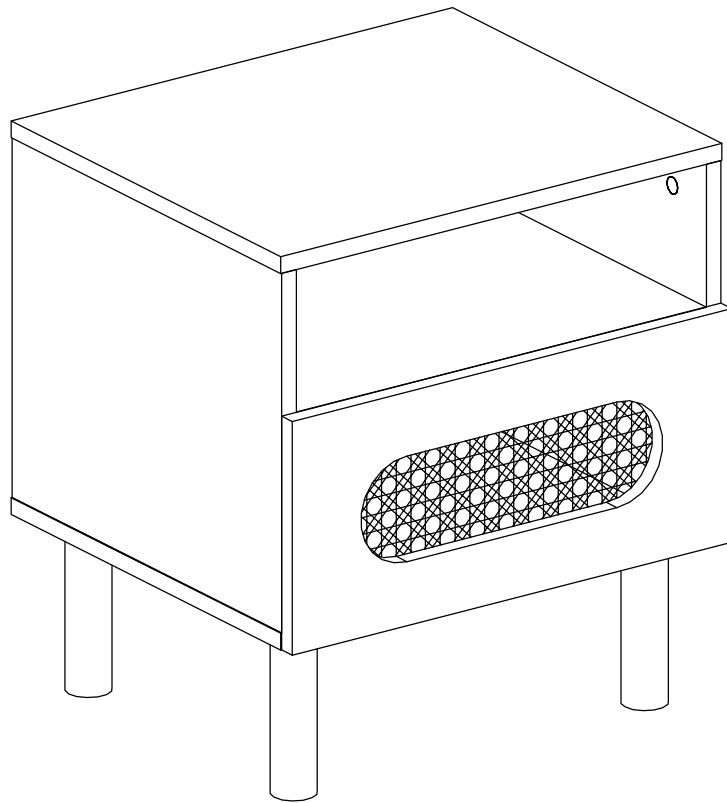

Kona Bedside Table-Maple
Kona Bedside Table-White
Dimensions:W450xD400xH500MM

IMPORTANT:-
PLEASE READ THESE INSTRUCTION CAREFULLY BEFORE STARTING ASSEMBLY.

IMPORTANT TIPS AND MAINTENANCE



i) Keep children and animal away to avoid choking hazard.

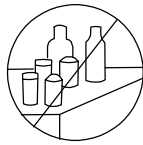

ii) Never put the liquid on the furniture.

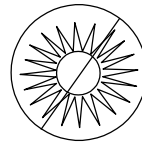

iii) To avoid dulling, do not place directly to the sunlight.



iv) Never use ammonia cleaning product, because it will damage the finish.

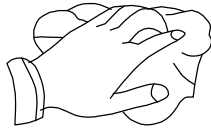

v) Use a dry cloth to wipe clean the surface.

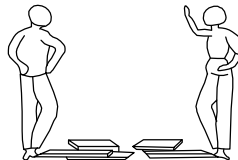



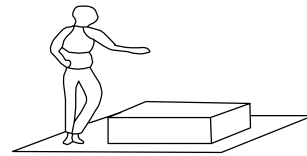



vi) Two person required.

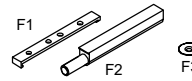

vii) Put a soft mat on the floor to protect the furniture before assembly.

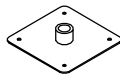
COMPONENTS:- HARDWARE	Please check you have all the fittings part or tools are listed in below.
----------------------------------	---

NO.	FITTINGS/TOOLS	QTY	NO.	FITTINGS/TOOLS	QTY
A.	 DOWEL 8x40MM	8 Pcs	F.	 F1 F2 F3	1 Sets
B.	 CAMBOLT+CAMNUT	16 Sets	G.	 DRAWER RUNNER-A&B	2 Pcs
C.	 SCREW M3.5x14MM	36 Pcs	H.	 SCREW M3.5x35MM	4 Pcs
D.	 	4 Pcs	I.	 	16 Pcs
E.	 	4 Pcs			

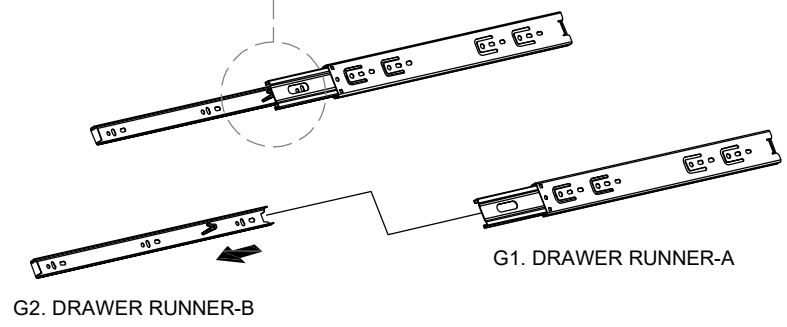
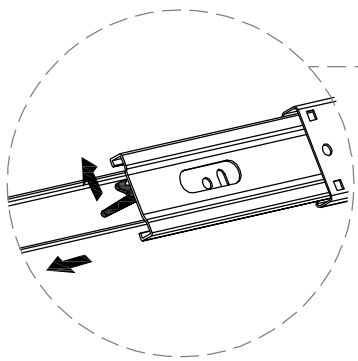

COMPONENTS:-
PANELS



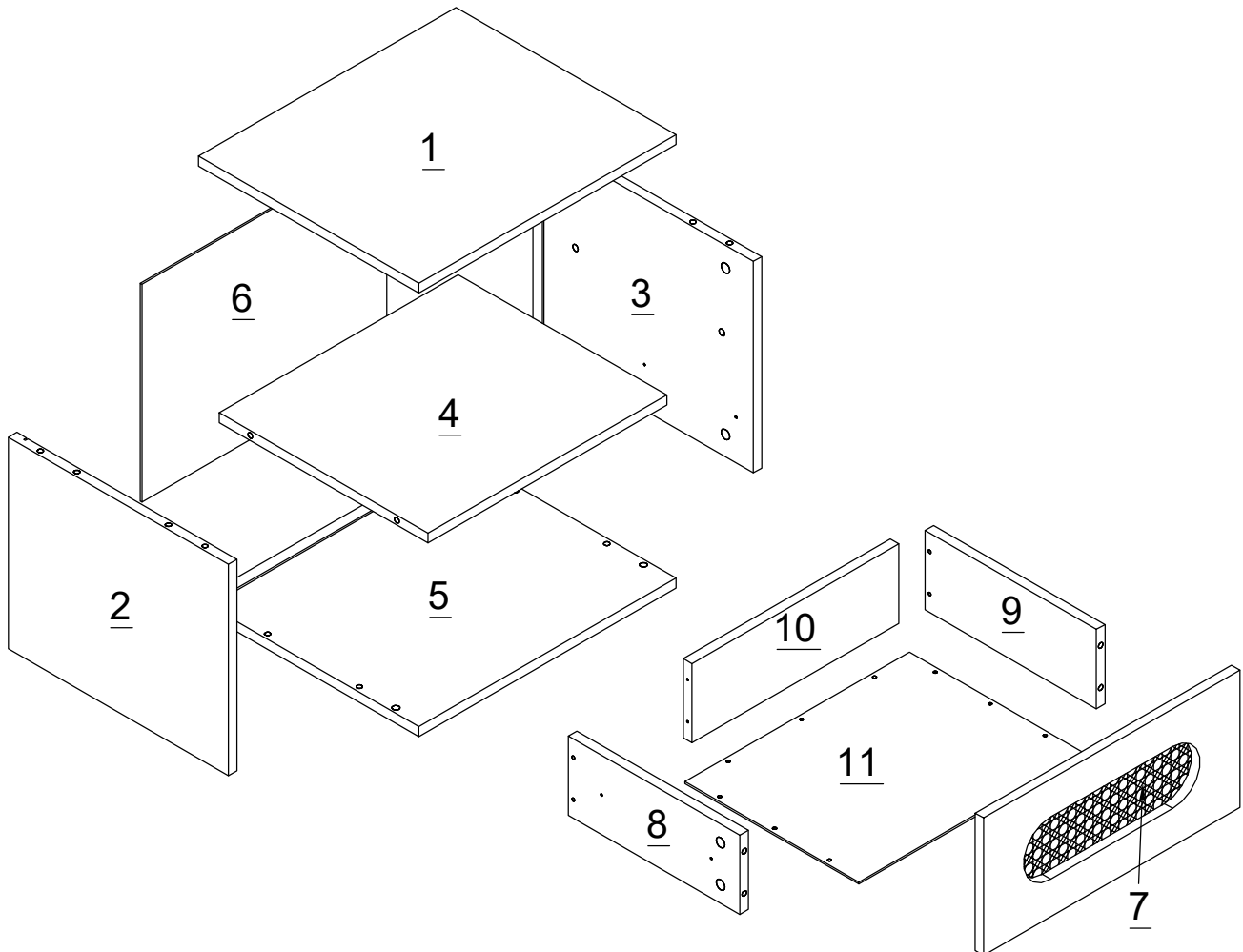

Please check you have all the panels are listed below.



PARTLIST

1	TOP PANEL	1pc	7	DRAWER FACE	1pc
2	SIDE PANEL-LEFT	1pc	8	DRAWER SIDE - LEFT	1pc
3	SIDE PANEL-RIGHT	1pc	9	DRAWER SIDE - RIGHT	1pc
4	CORSS SHELF	1pc	10	DRAWER END	1pc
5	BOTTOM PANEL	1pc	11	DRAWER BOTTOM	1pc
6	BACK PANEL	1pc			

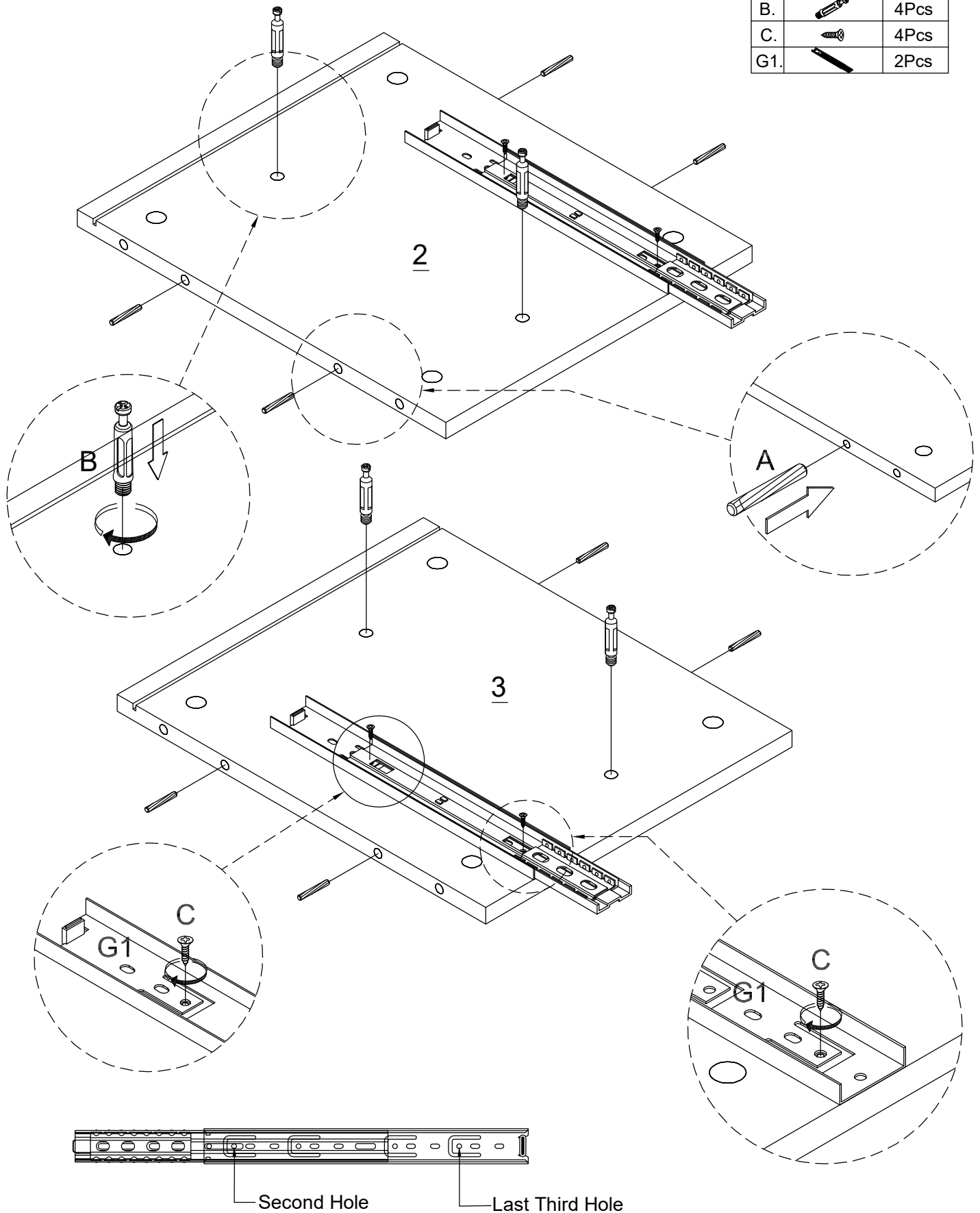

STEP 1

HARDWARE NEEDED:		
A.		8Pcs
B.		4Pcs
C.		4Pcs
G1.		2Pcs



SCREW MUST BE INSERTED
IN THE SECOND HOLE ON THE
DRAWER RUNNER

STEP2

HARDWARE NEEDED:		
C.		2Pcs
F1.		1Pc
F2.		1Pc

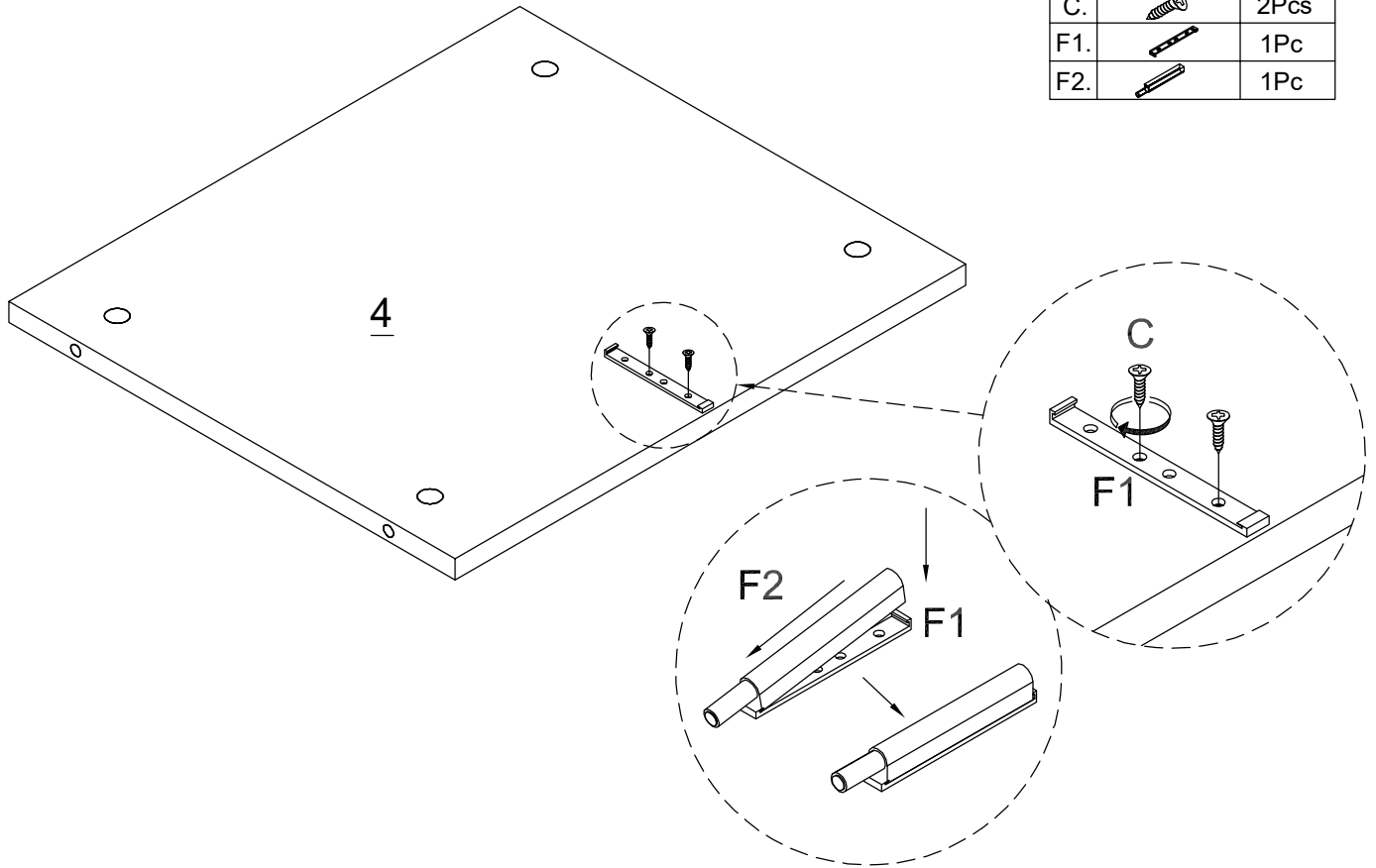

STEP3

HARDWARE NEEDED:		
B.		4Pcs

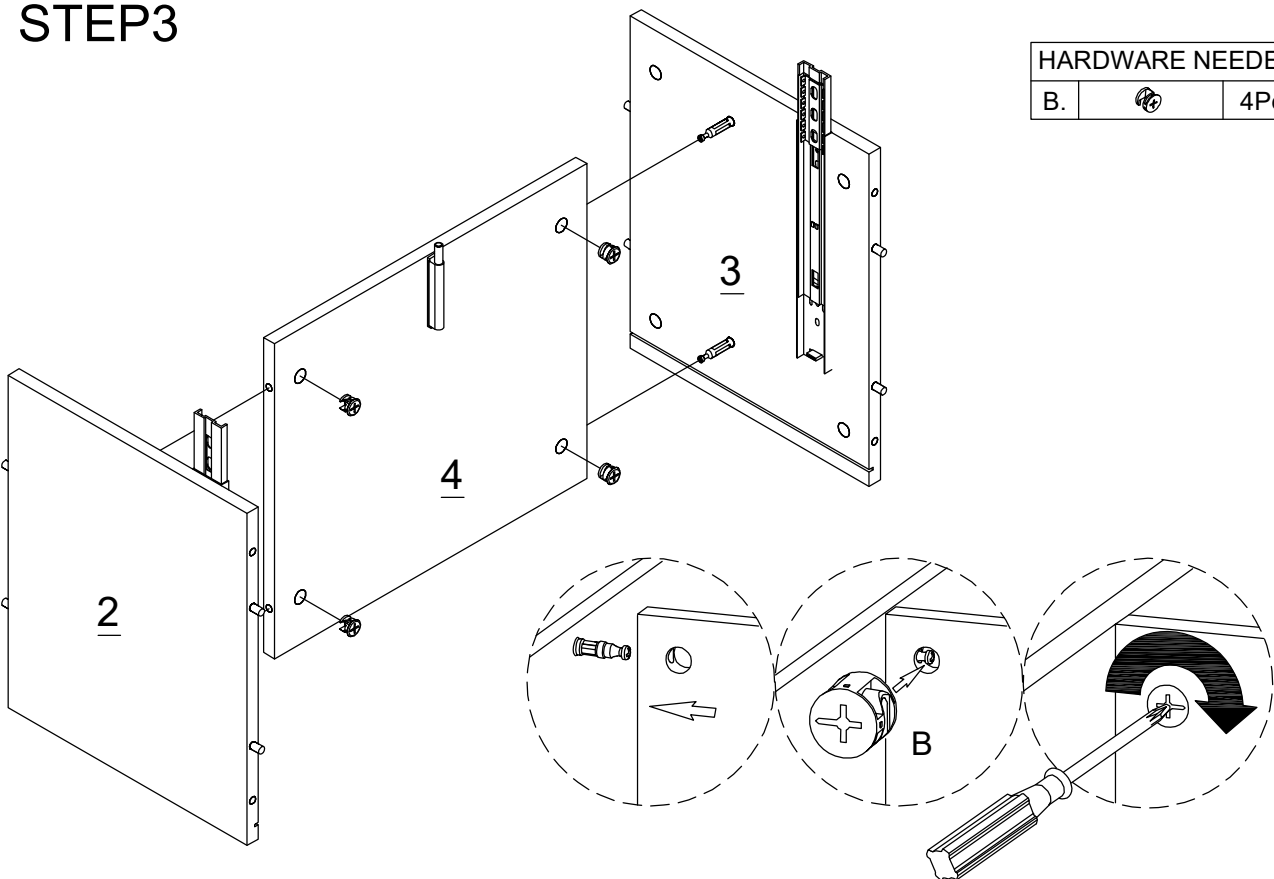

STEP4

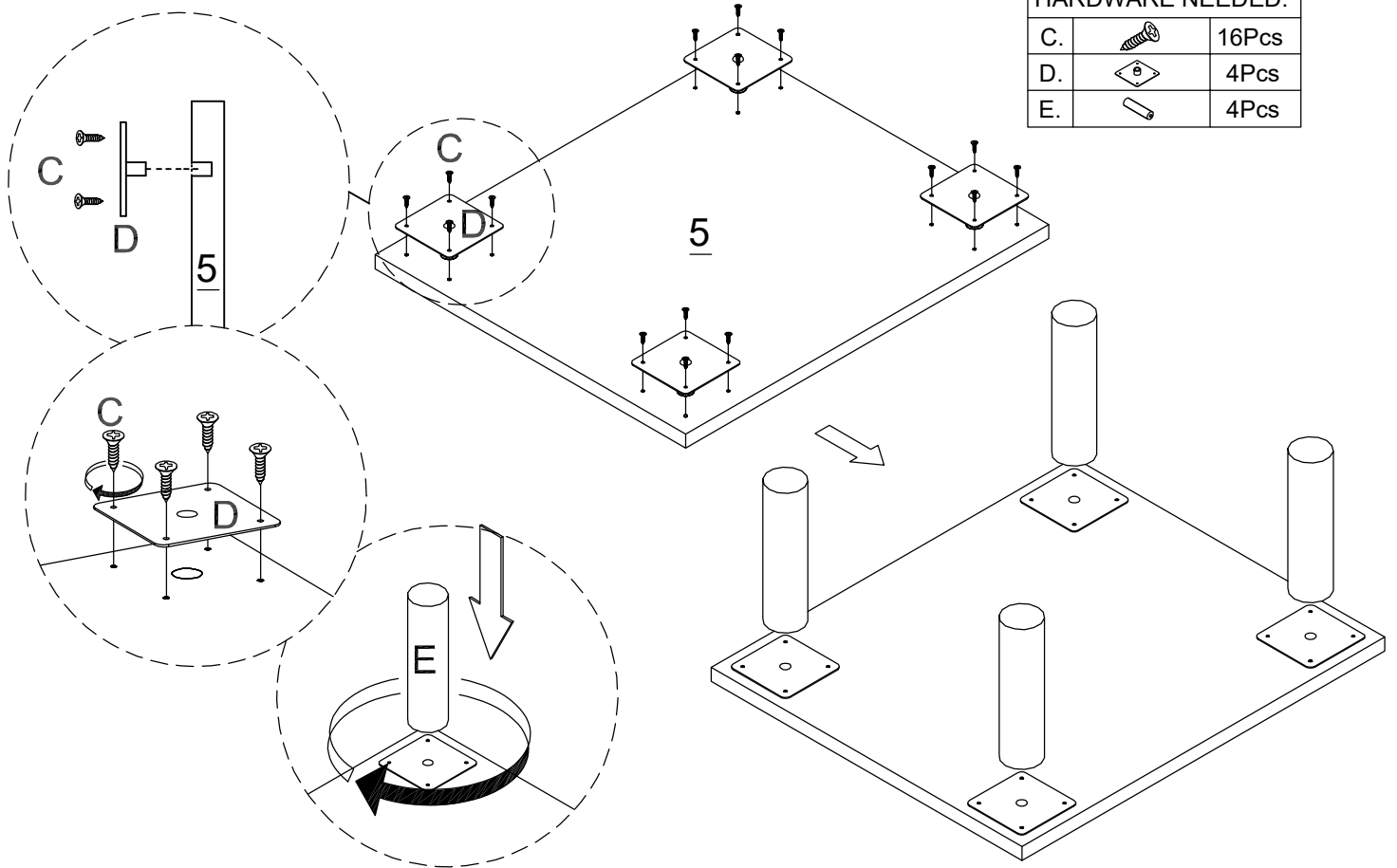

STEP5

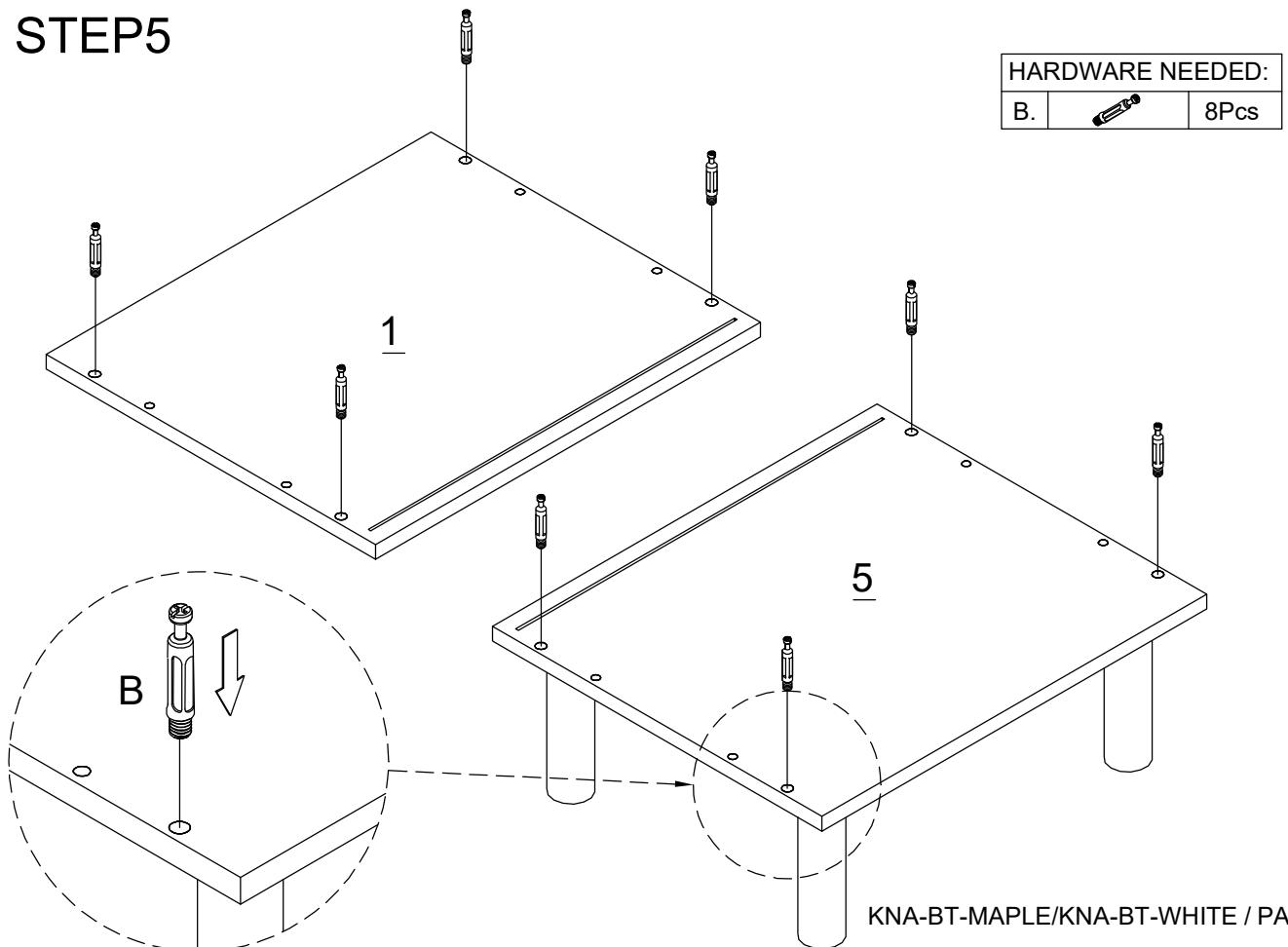

STEP6

HARDWARE NEEDED:		
B.		4Pcs

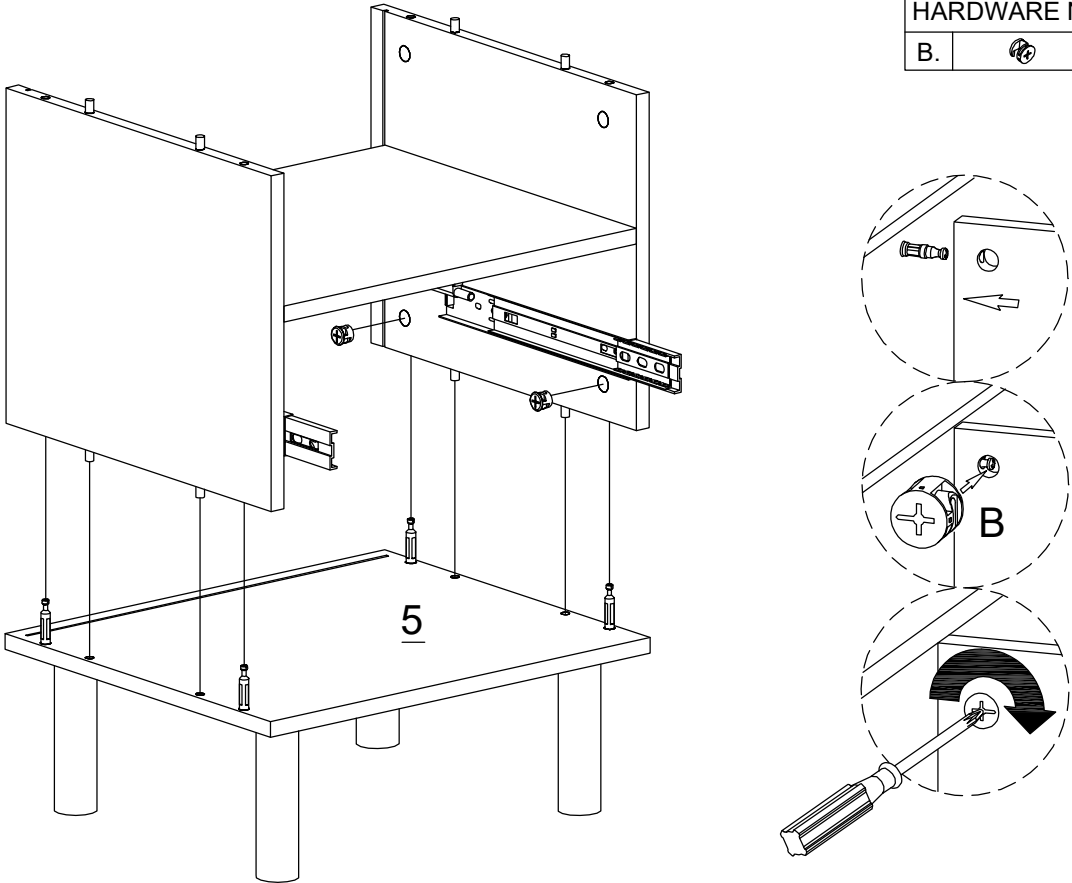

STEP7

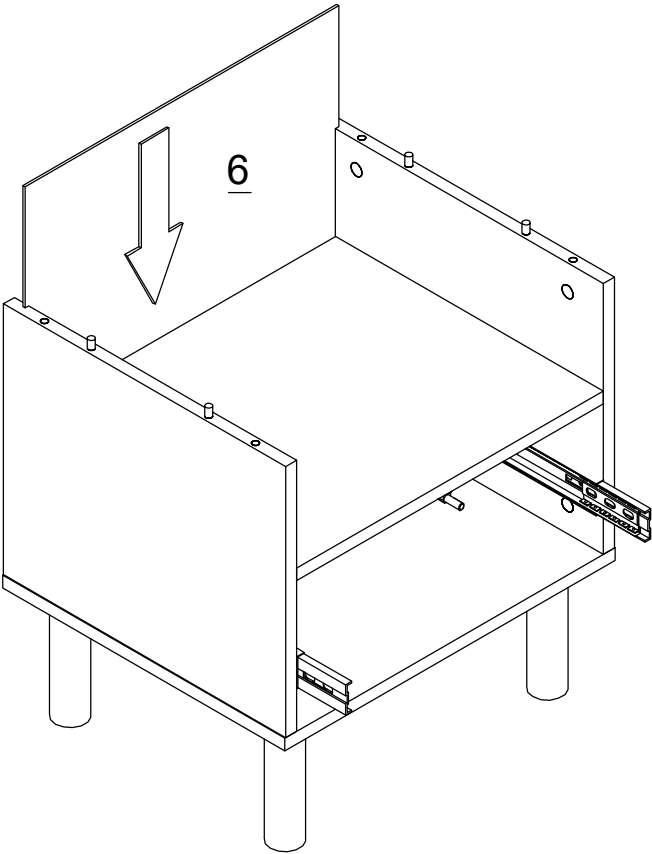

STEP8

HARDWARE NEEDED:

B.		4Pcs
----	---	------

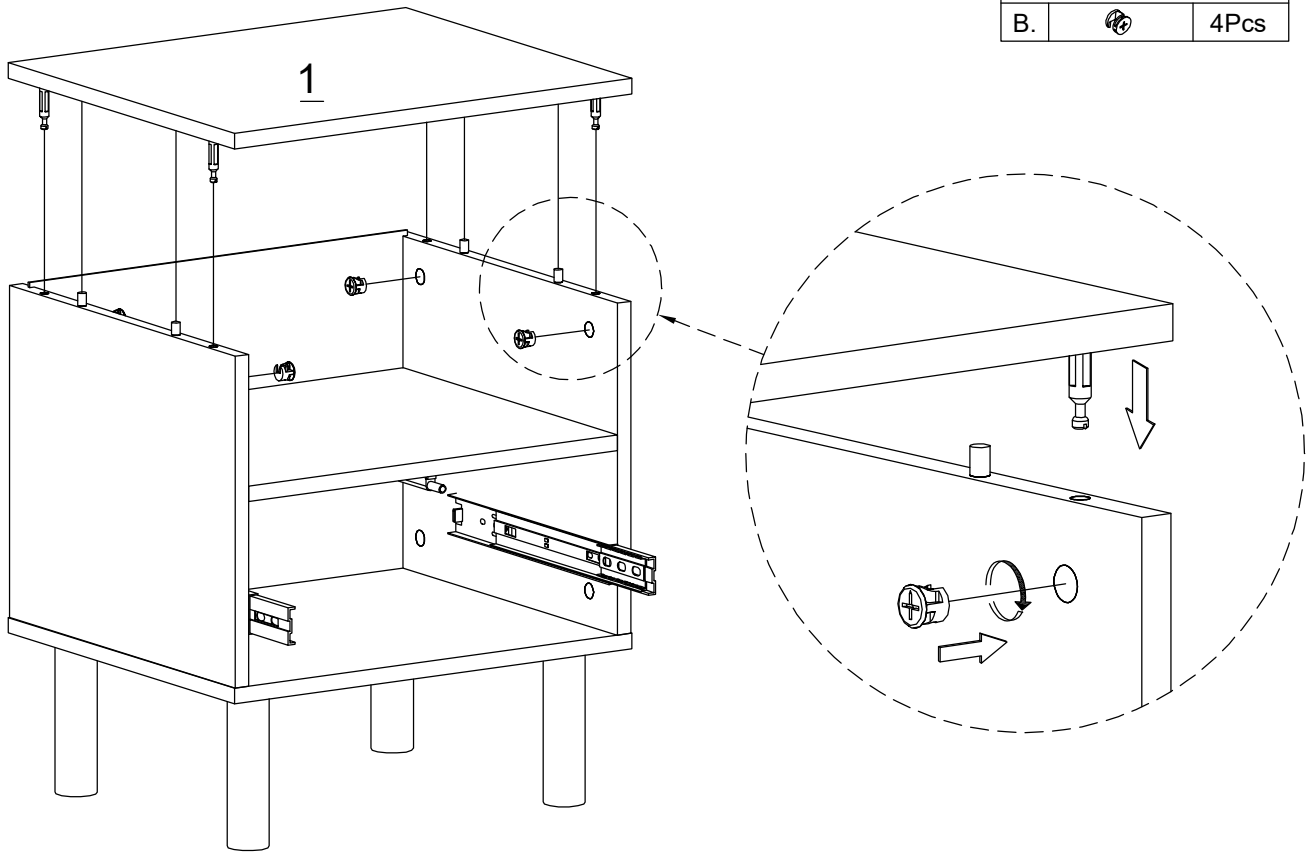

STEP9

HARDWARE NEEDED:

C.		9Pcs
H.		4Pcs

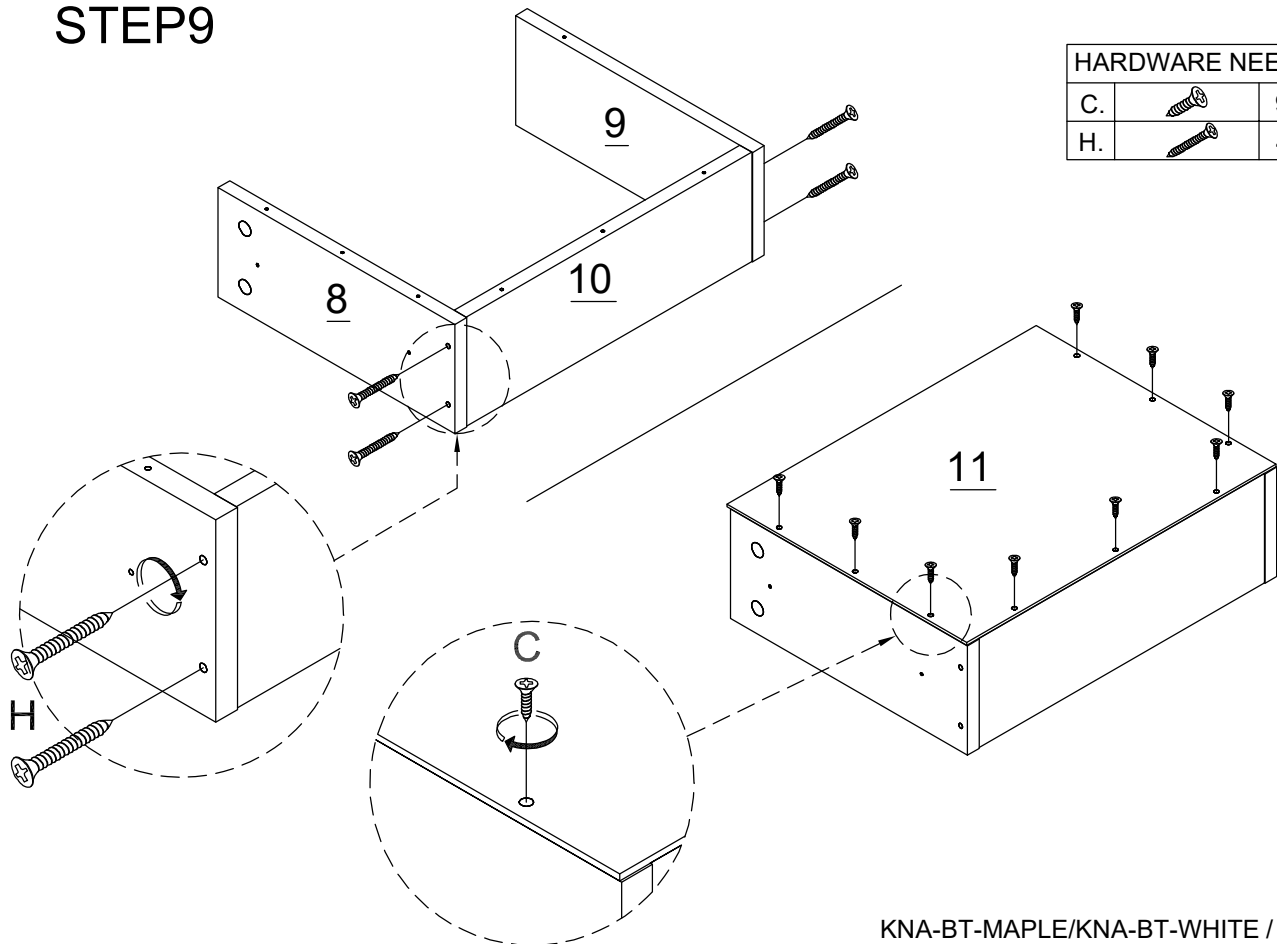

STEP10

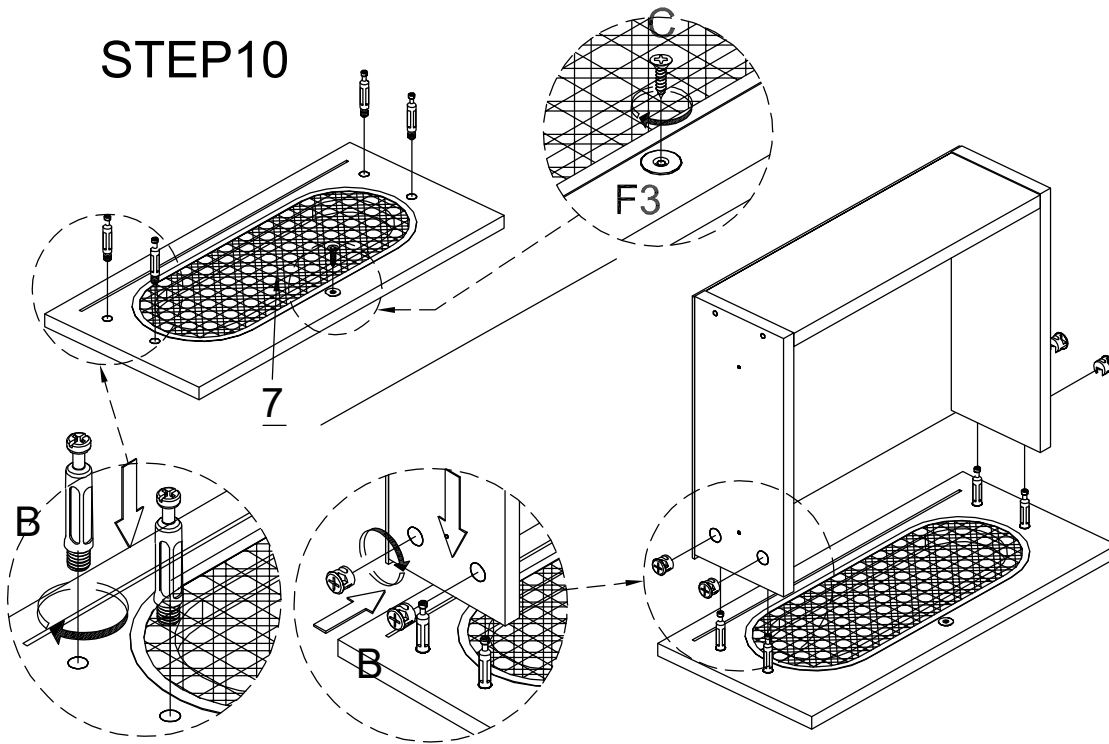

HARDWARE NEEDED:		
B.		4Sets
C.		5Pcs
F3.		1Pc
G2.		2Pcs

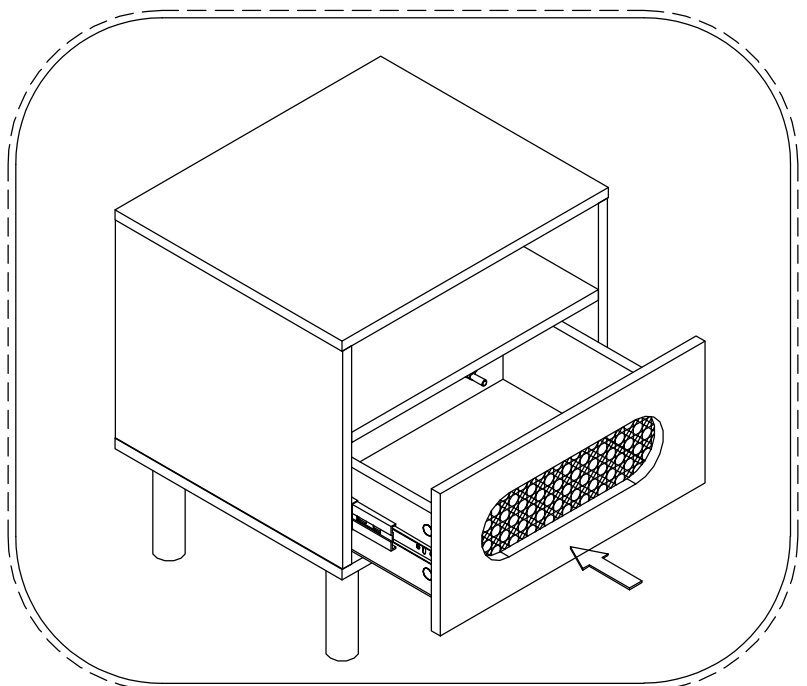
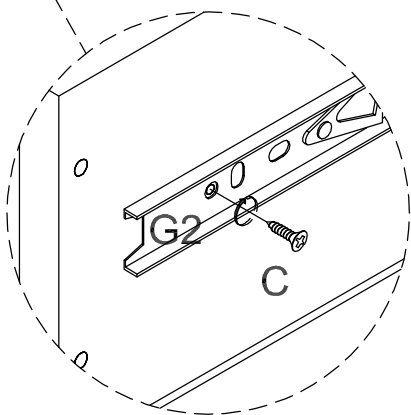
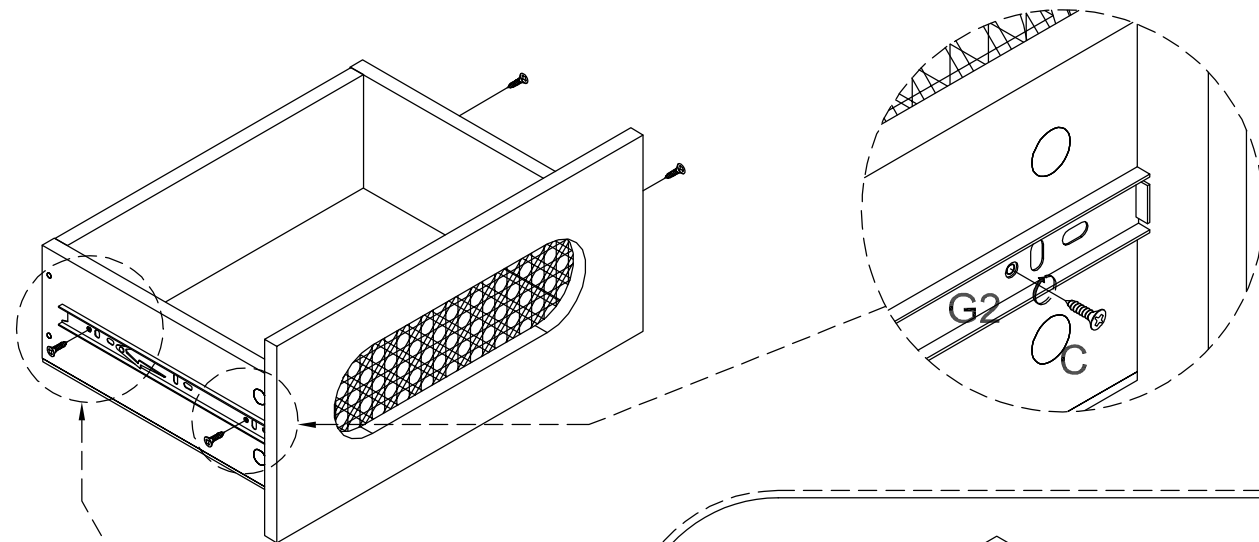

STEP11

HARDWARE NEEDED:		
I.		16Pcs

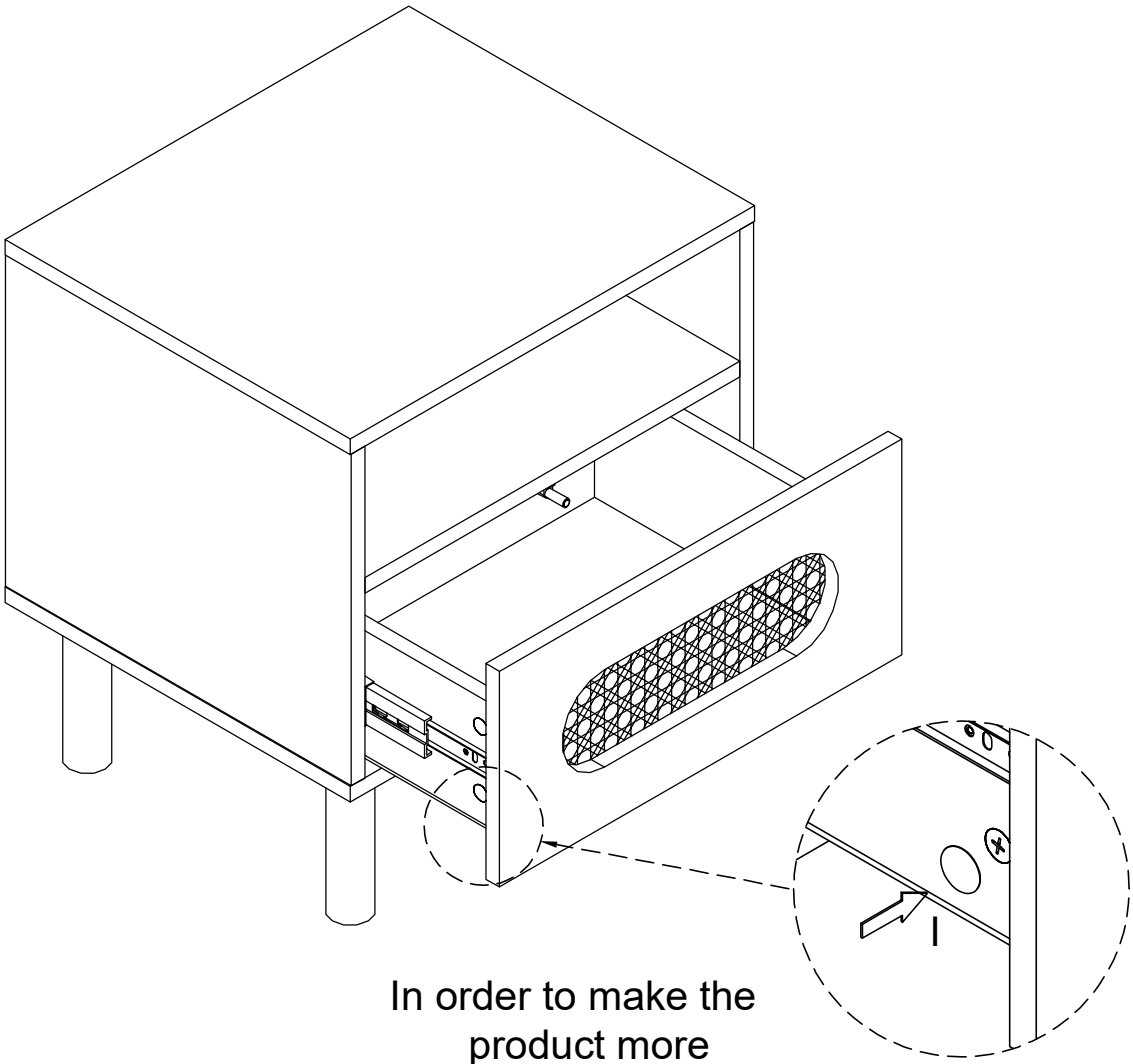

In order to make the product more beautiful, please paste hardware K on the exposed holes