

*Please Keep For Future Reference Only.

MUZI SERIES ASSEMBLY INSTRUCTION

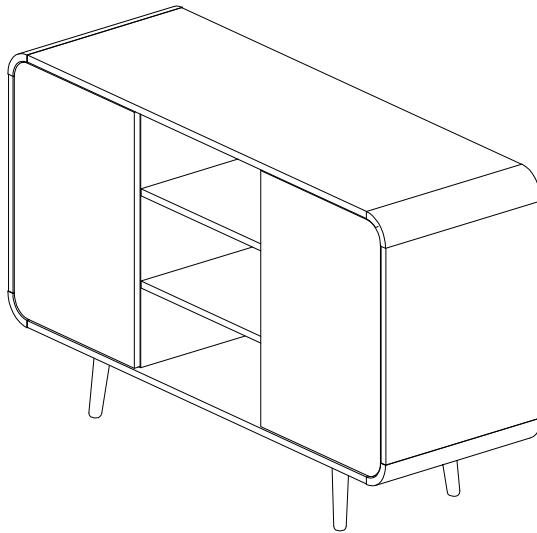

Dimensions

Width:1200mm

Depth:400mm

Height:750mm

MUZI SIDE BOARD

IMPORTANT:-
PLEASE READ THESE INSTRUCTION CAREFULLY BEFORE STARTING ASSEMBLY.

IMPORTANT TIPS AND MAINTENANCE



i) Keep children and animal away to avoid choking hazard.



ii) Never put the liquid on the furniture.

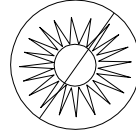

iii) To avoid dulling, do not place directly to the sunlight.



iv) Never use ammonia cleaning product, because it will damage the finish.



v) Use a dry cloth to wipe clean the surface.

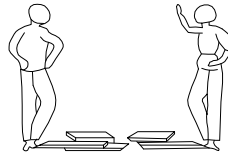



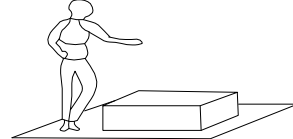



vi) Two person required.



vii) Put a soft mat on the floor to protect the furniture before assembly.

COMPONENTS:- HARDWARE

Please check you have all the fittings part or tools are listed in below.

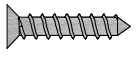
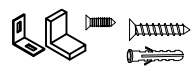
NO.	FITTINGS/TOOLS	QTY	NO.	FITTINGS/TOOLS	QTY
A.	 DOWEL 8x40MM	36 Pcs	E.	 PUSH SWITCH	2 Sets
B.	 CAMBOLT+CAMNUT	32 Sets	F.	 HINGE	4 Pcs
C.	 SCREW M3.5x14MM	36 Pcs	J.	 	8 Pcs
D.	 SCREW M4x40MM	20 Pcs	K.	 	2 Sets

COMPONENTS:-
PANELS

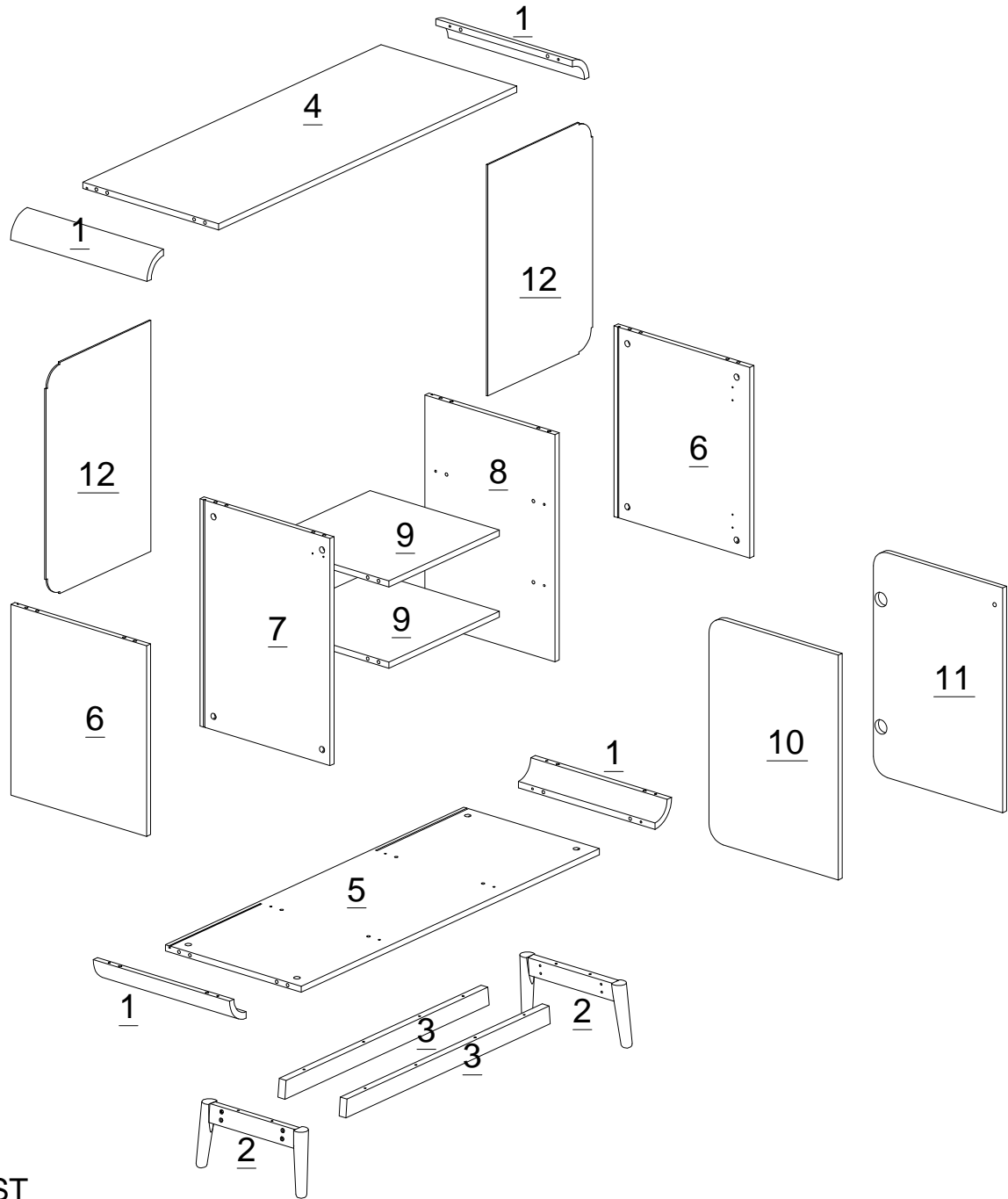

Please check you have all the panels are listed below.



PARTLIST

1	ARC EDGE	4pcs	8	MIDDLE PANEL_R	1pc
2	LEG	2pcs	9	SHELF PANEL	2pcs
3	BRACE PANEL	2pcs	10	DOOR_L	1pc
4	TOP PANEL	1pc	11	DOOR_R	1pc
5	BOTTOM PANEL	1pc	12	BACK PANEL	2pcs
6	SIDE PANEL	2pcs			
7	MIDDLE PANEL_L	1pc			

STEP1

HARDWARE NEEDED:		
D.		8PCS
A.		4PCS

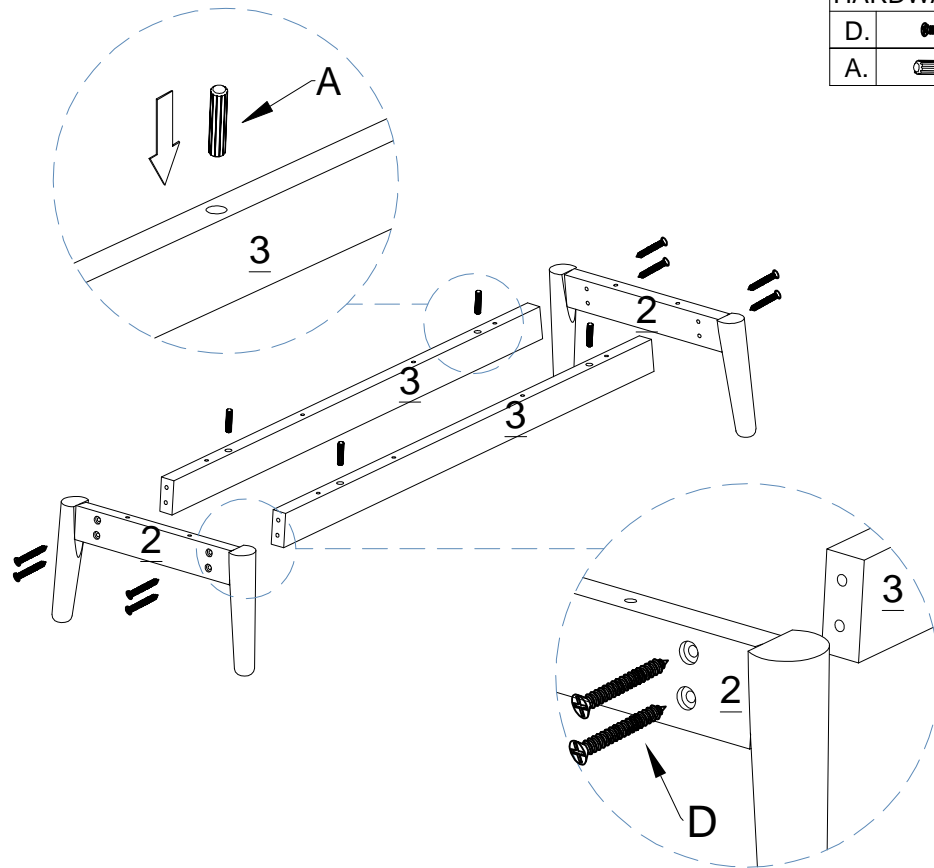

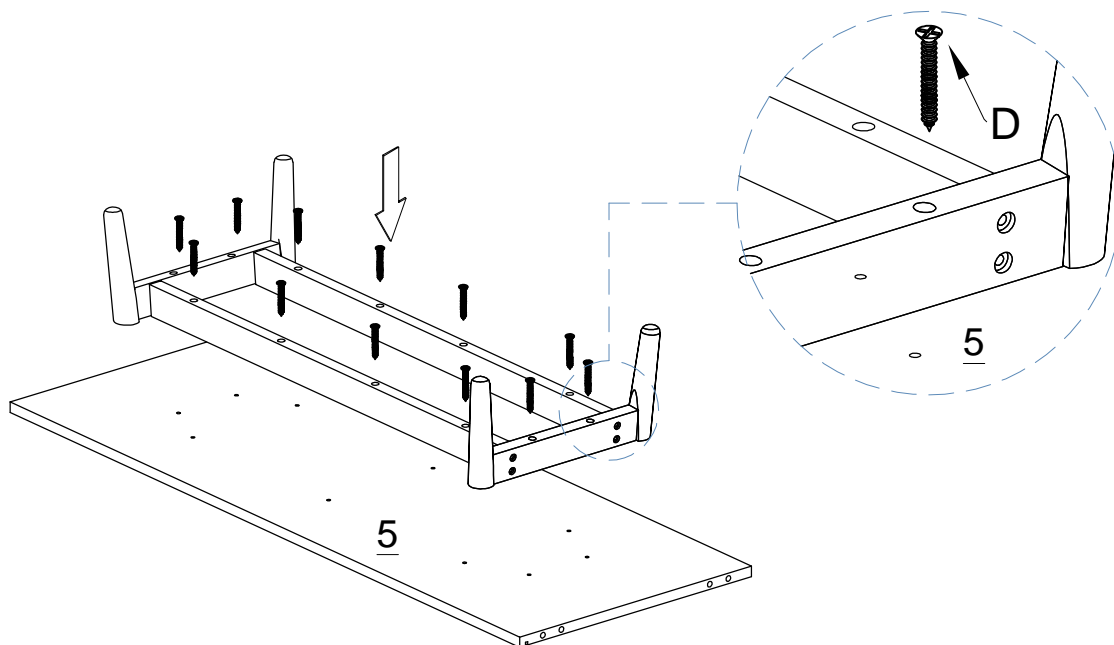

STEP2

HARDWARE NEEDED:		
D.		10PCS



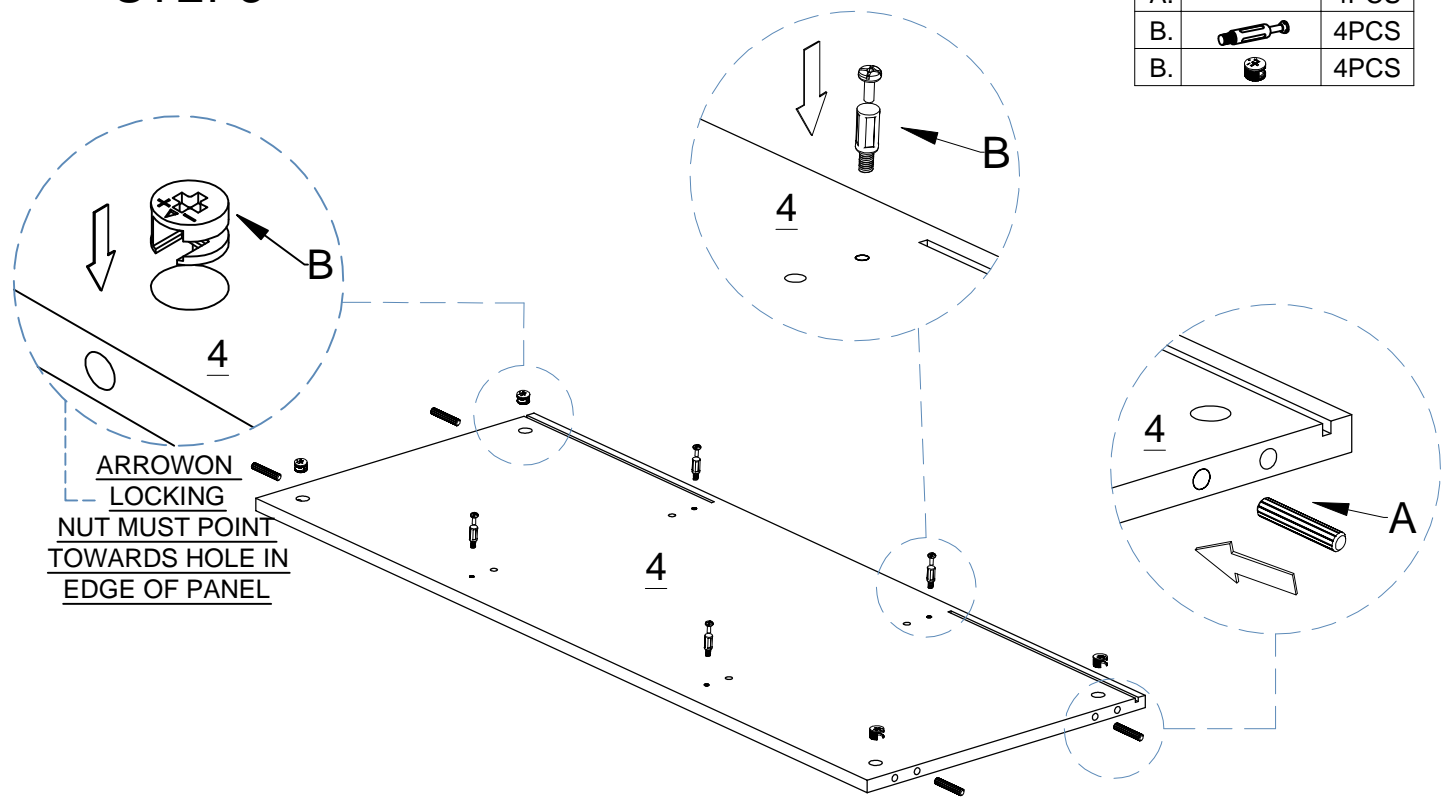

STEP3

HARDWARE NEEDED:		
A.		4PCS
B.		4PCS
B.		4PCS



STEP4

HARDWARE NEEDED:		
A.		4PCS
B.		4PCS
B.		4PCS

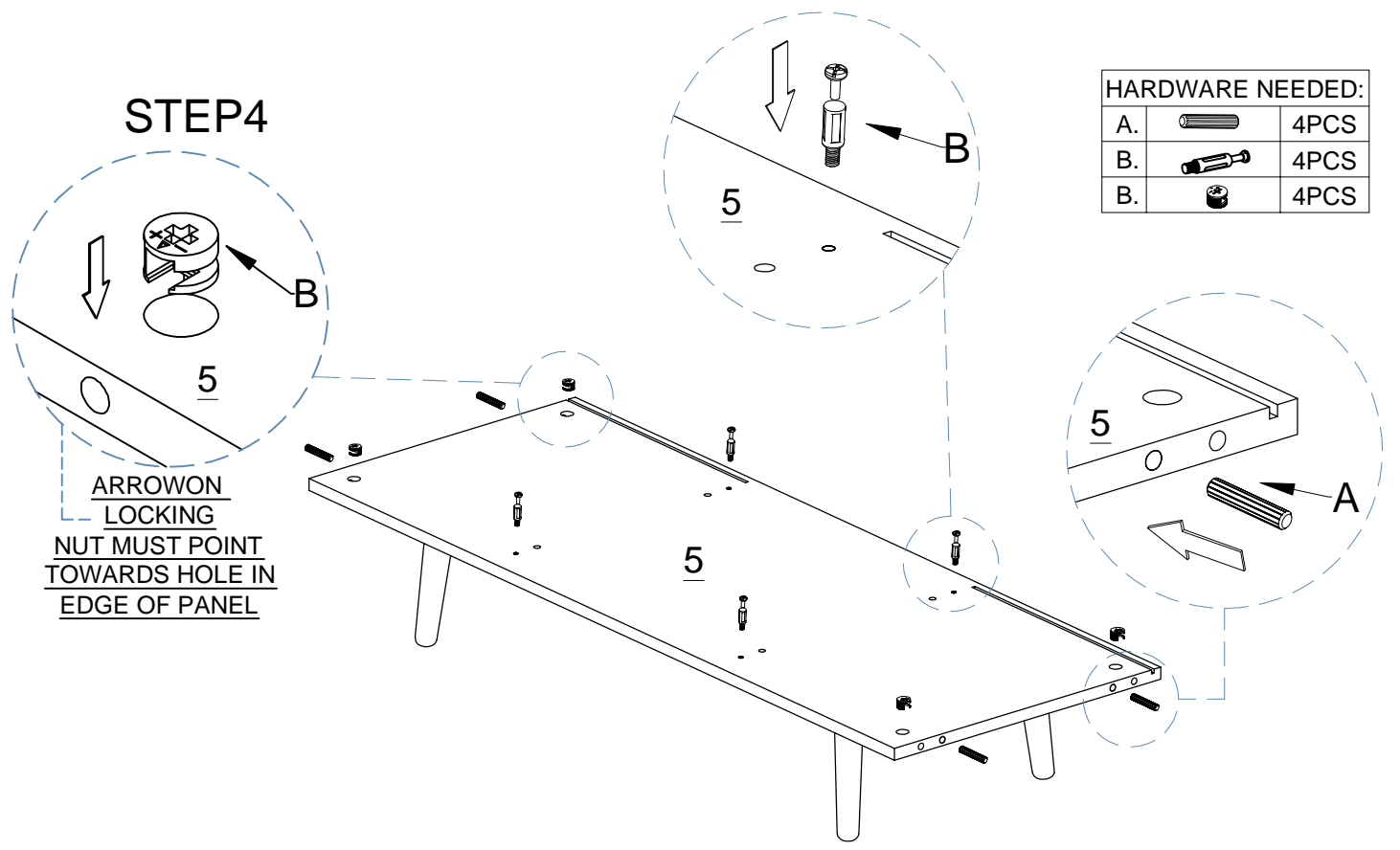

STEP5

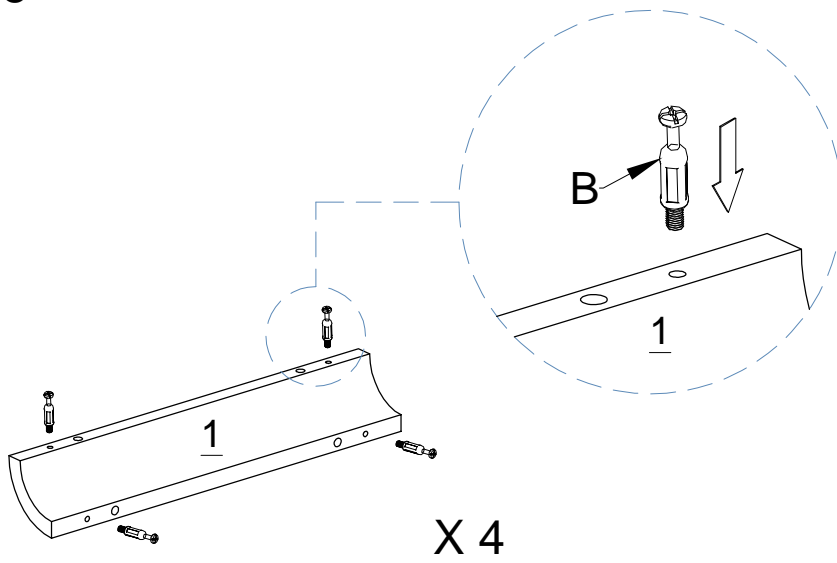

HARDWARE NEEDED:		
B.		16PCS

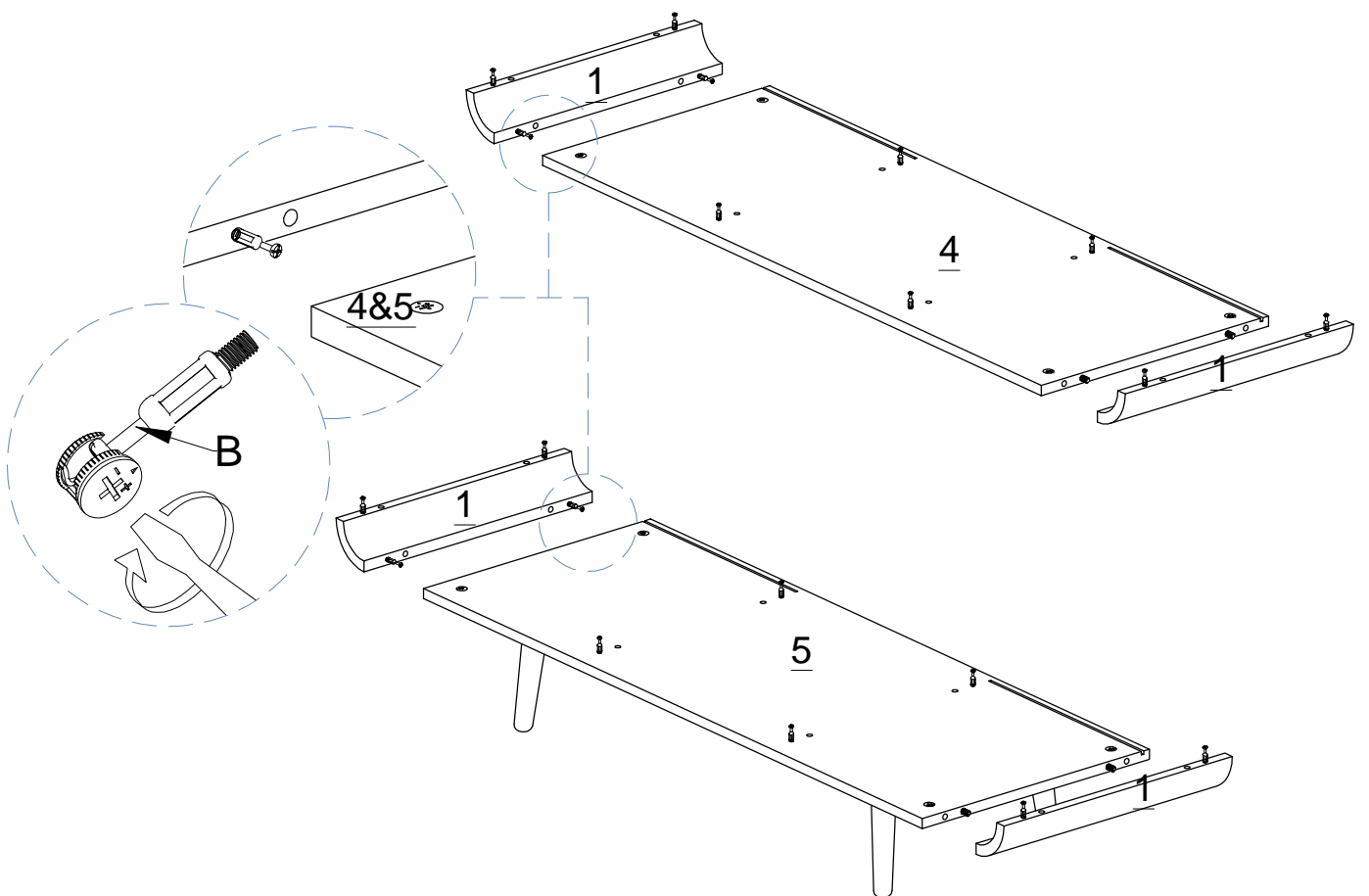

STEP6



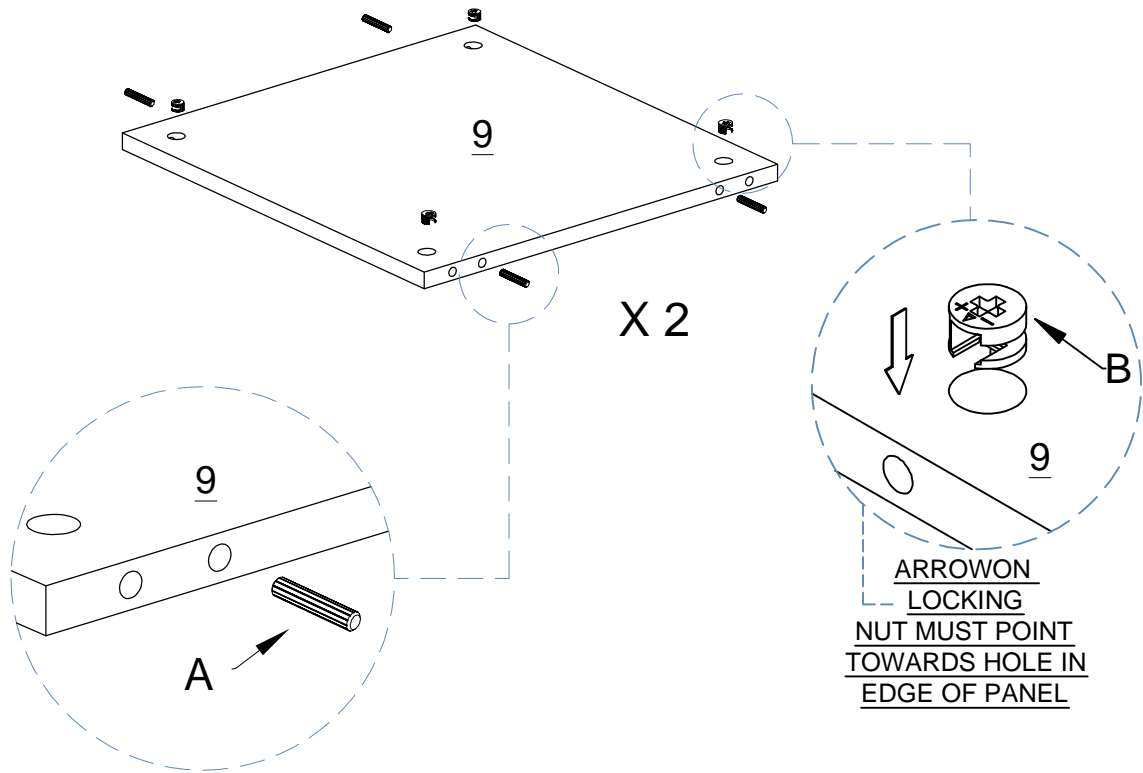

STEP 7

HARDWARE NEEDED:		
A.		8PCS
B.		8PCS



STEP 8

HARDWARE NEEDED:		
A.		8PCS
B.		8PCS

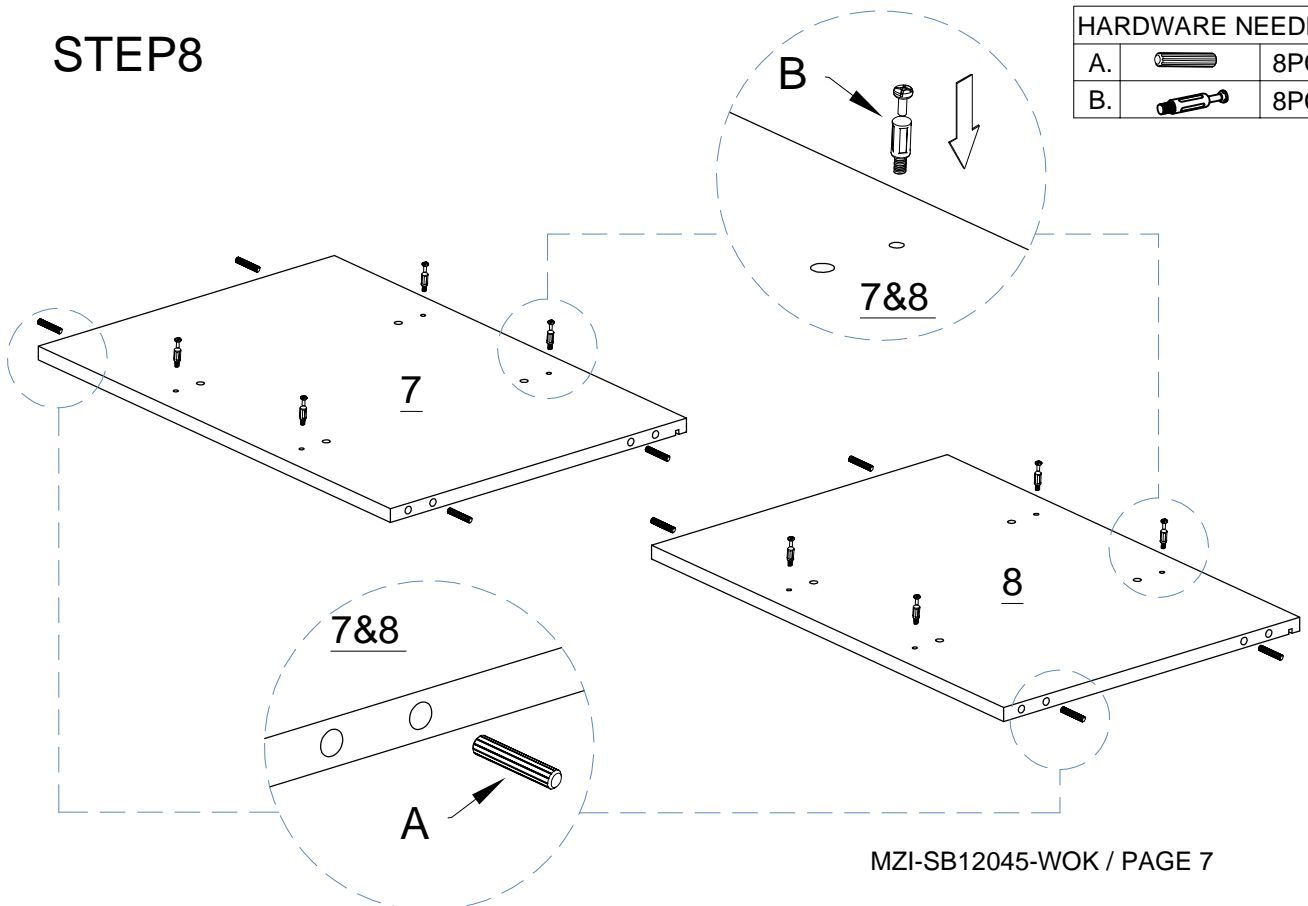

STEP9

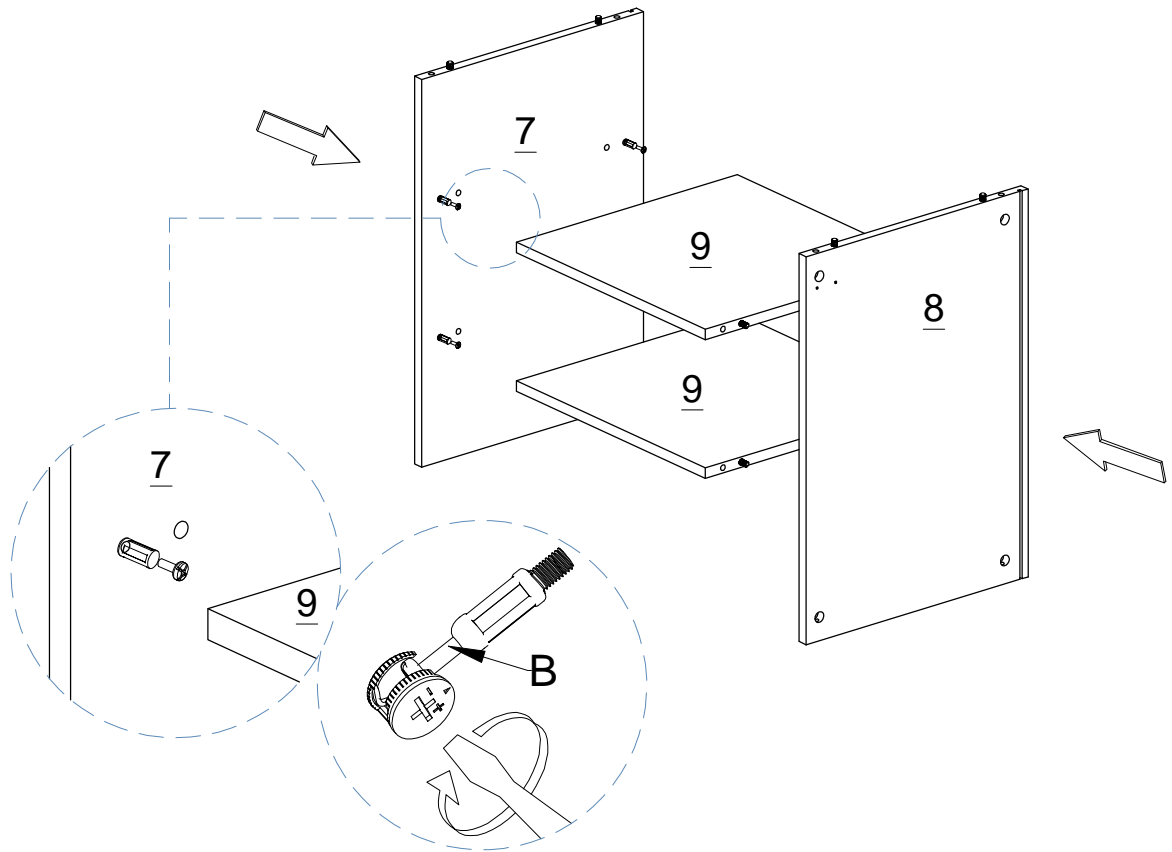

STEP10

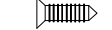

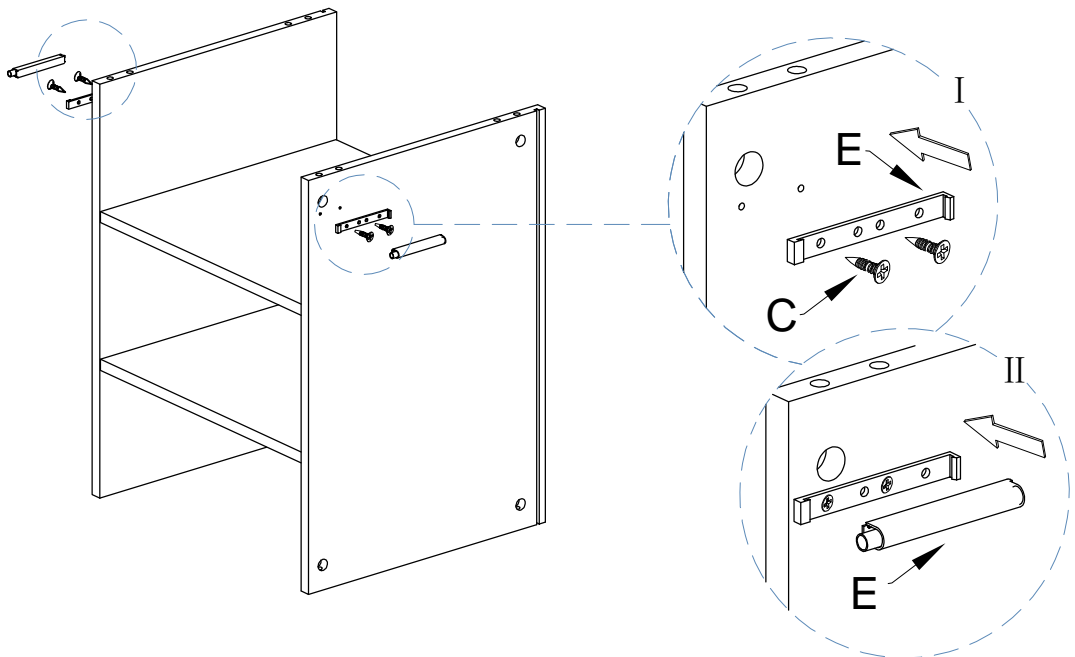
HARDWARE NEEDED:		
E.		2 SETS
C.		4PCS

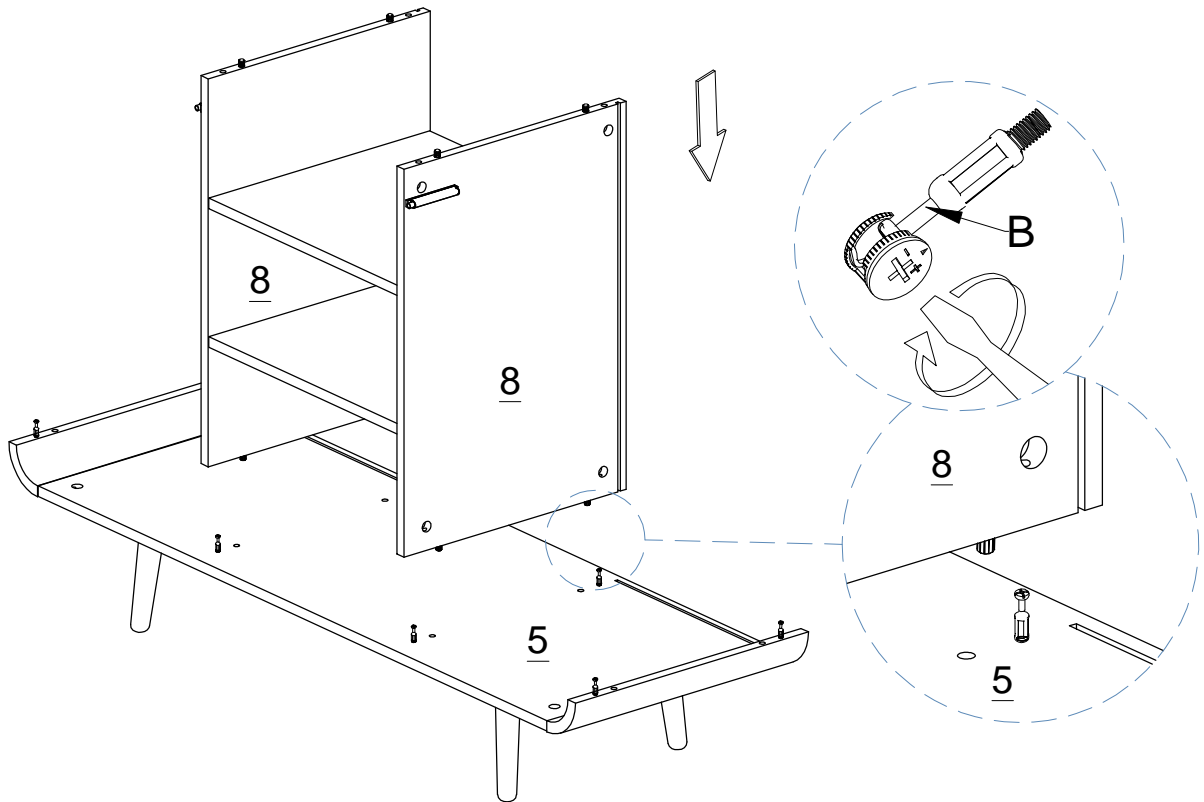

STEP11



STEP12

HARDWARE NEEDED:		
A.		8PCS
B.		8PCS

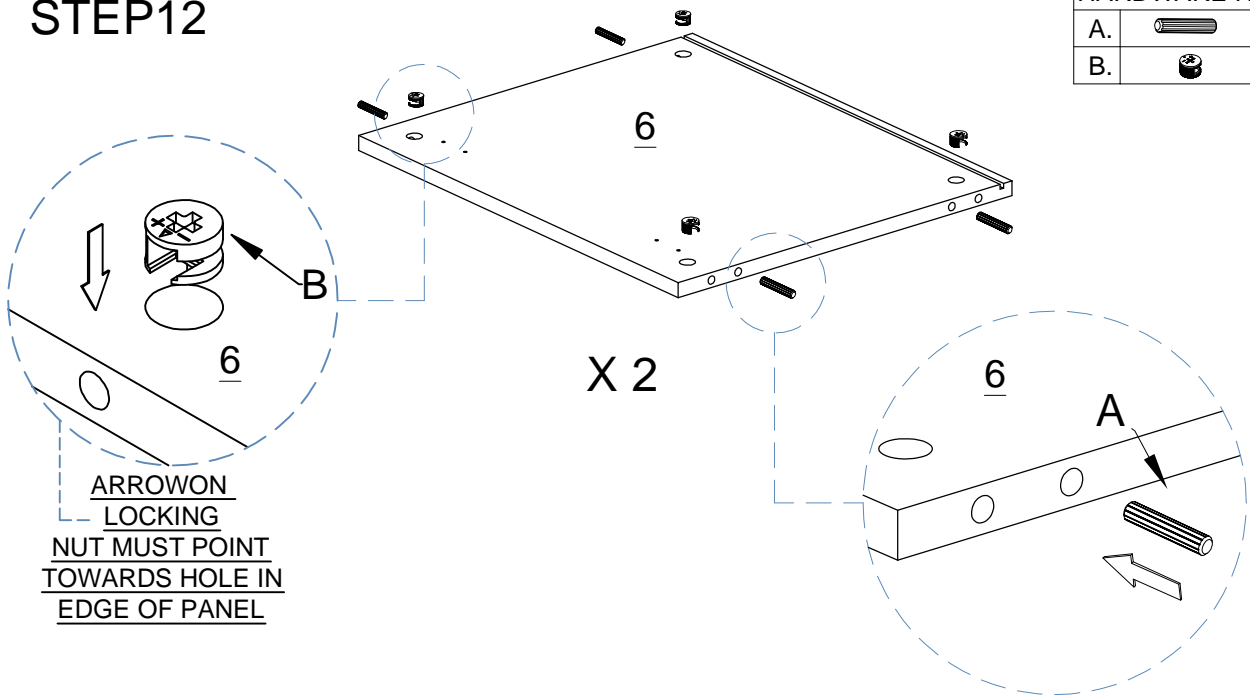

STEP13

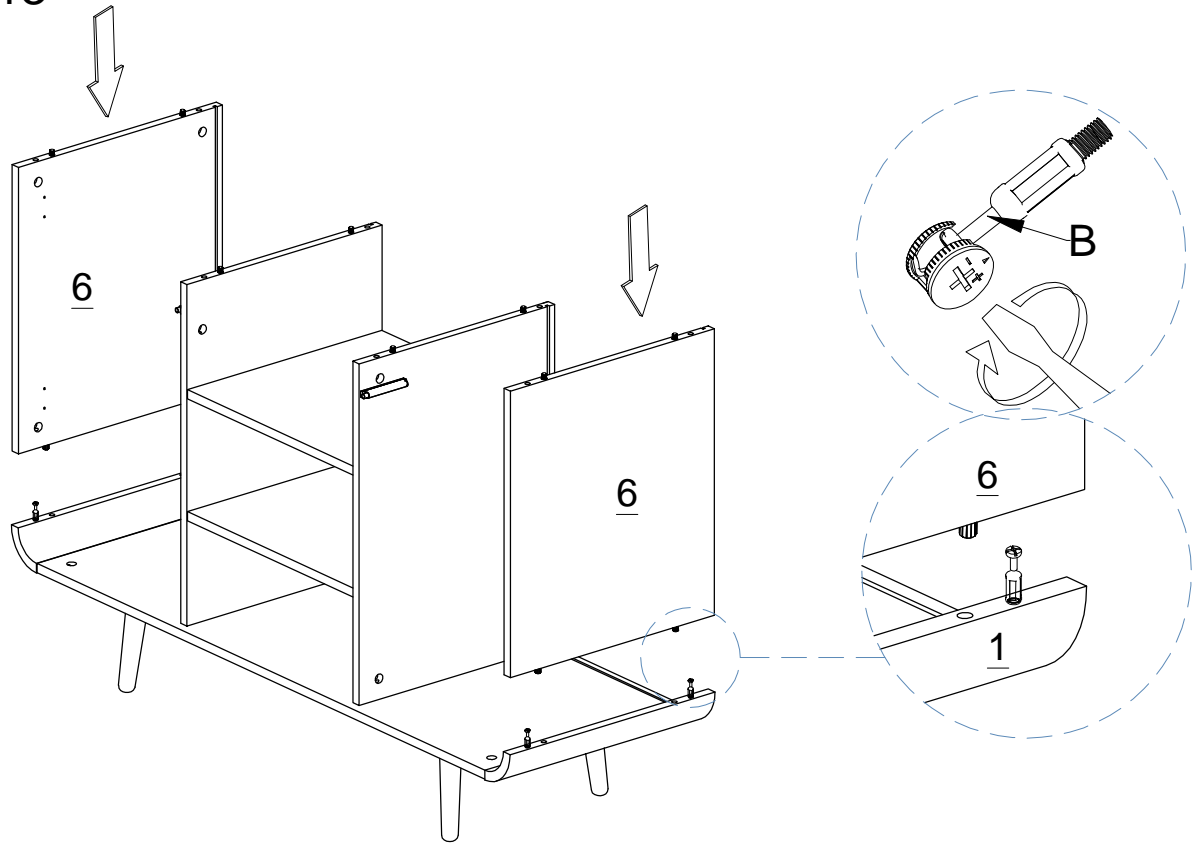



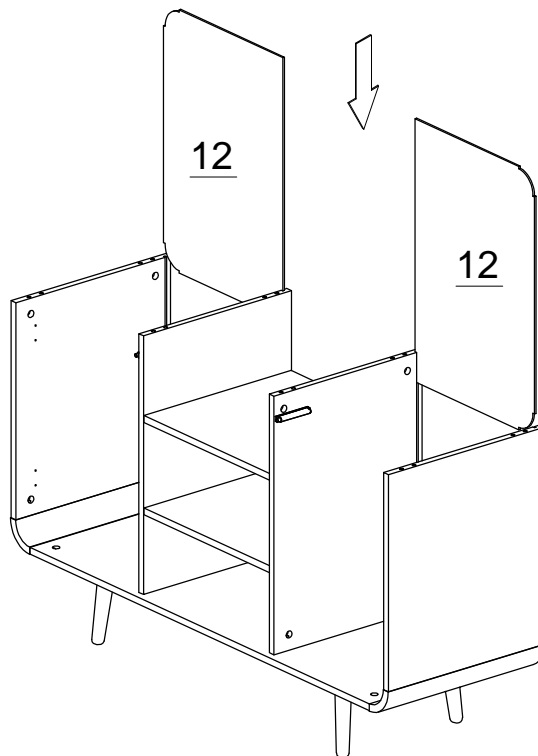

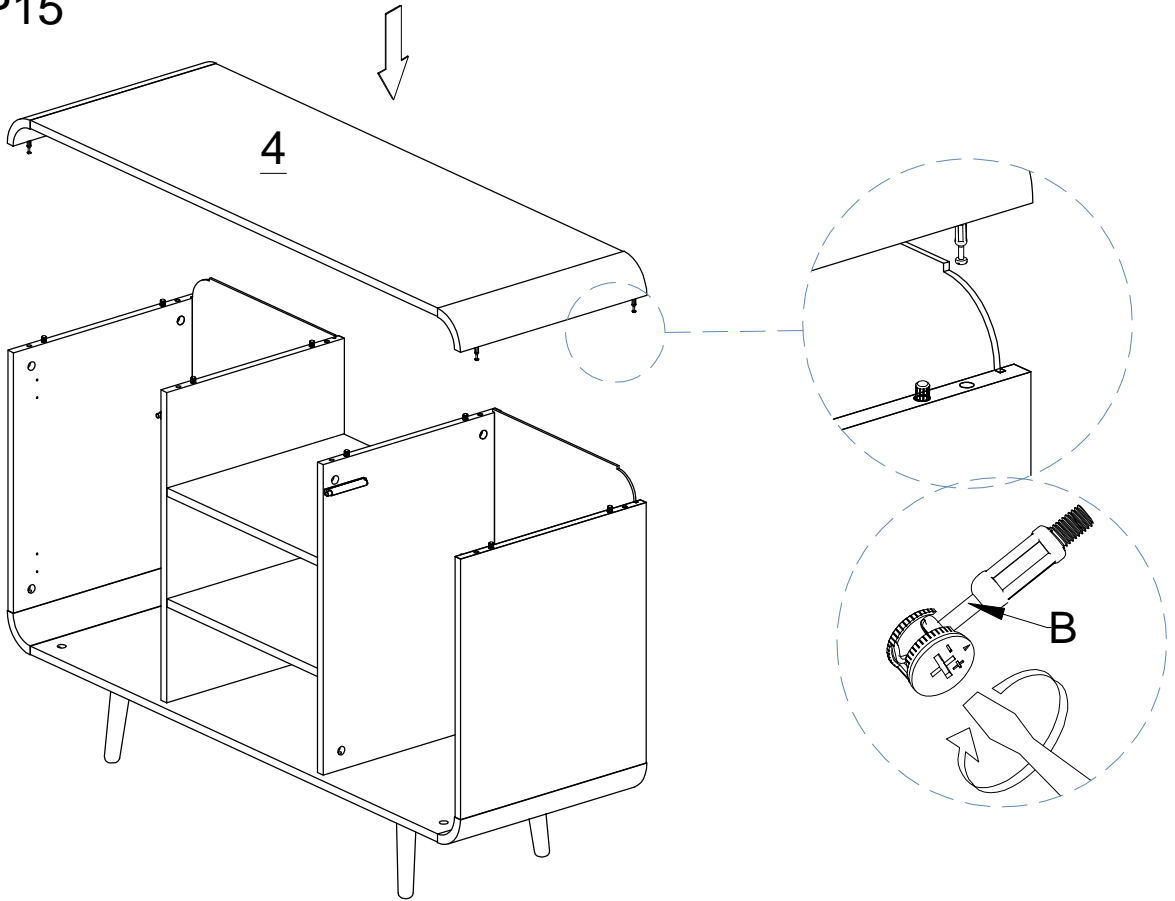

STEP14



STEP15



STEP16

HARDWARE NEEDED:		
E.	  	2 SETS
F.	 	4PCS
C.		8PCS

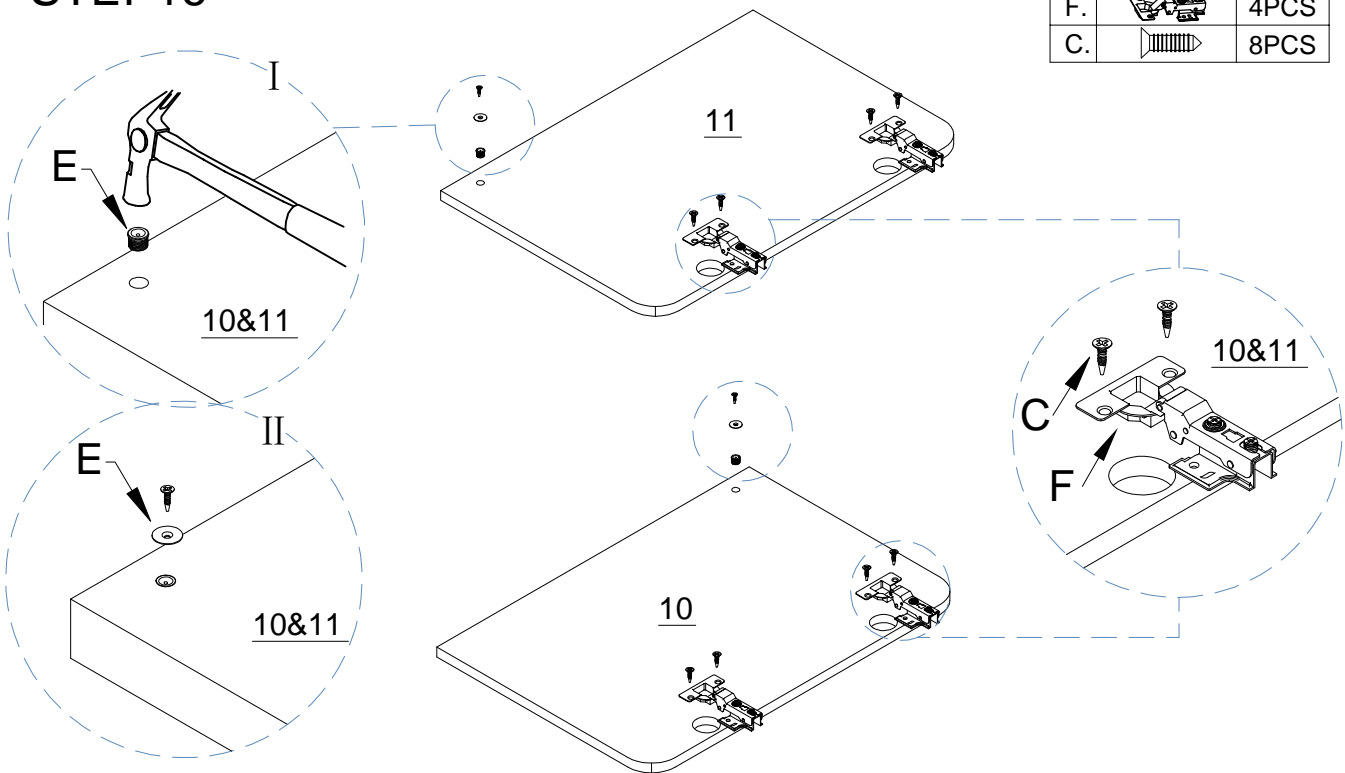

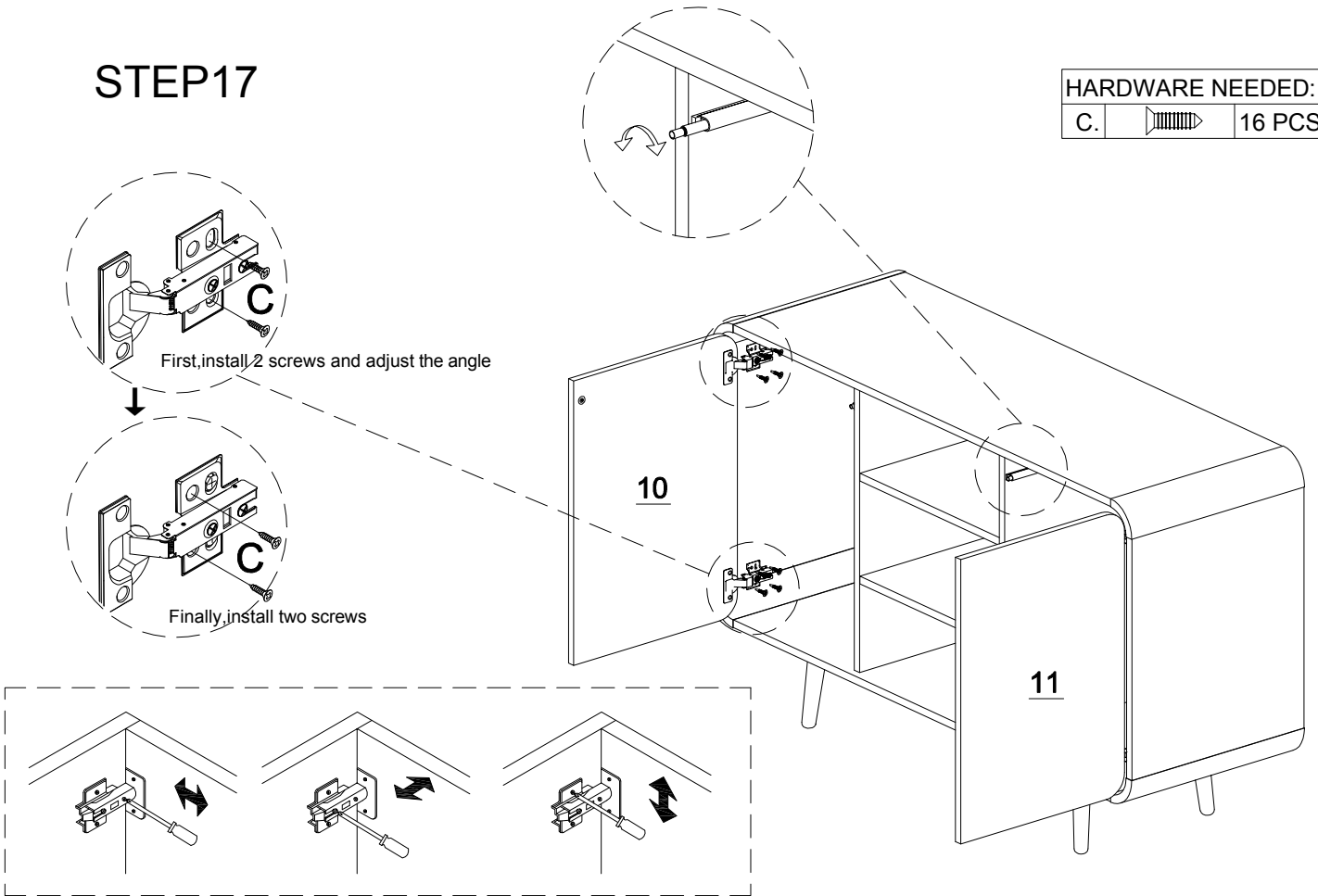

STEP17

HARDWARE NEEDED:		
C.		16 PCS



STEP18

HARDWARE NEEDED:		
J.		8 PCS
C.		8 PCS

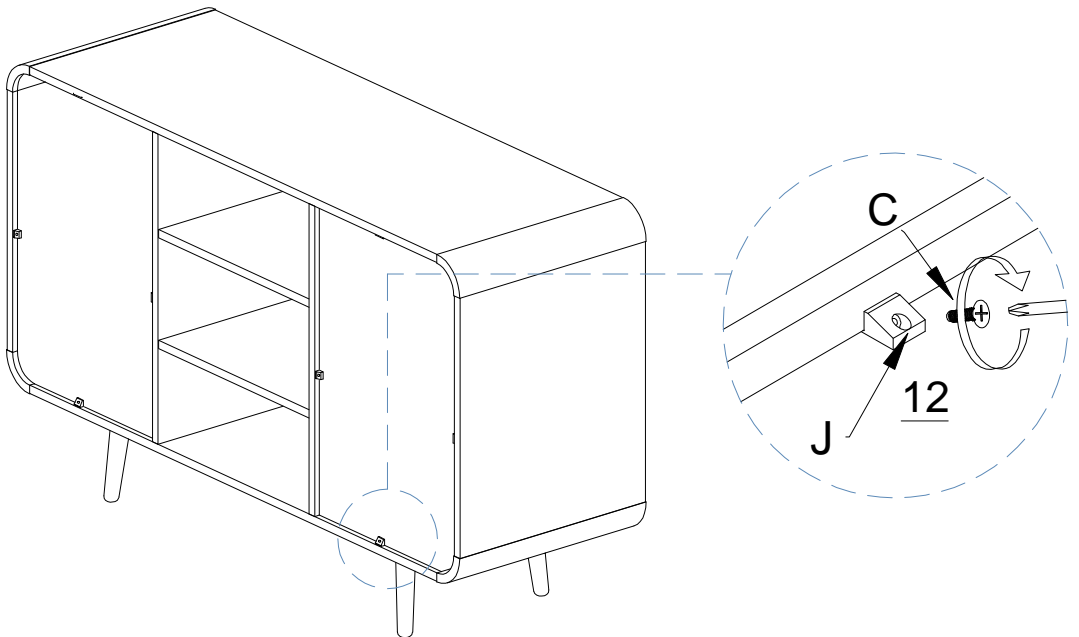

STEP19

HARDWARE NEEDED:			
K.			2SETS

