

Assembly Instruction

Nobu Series

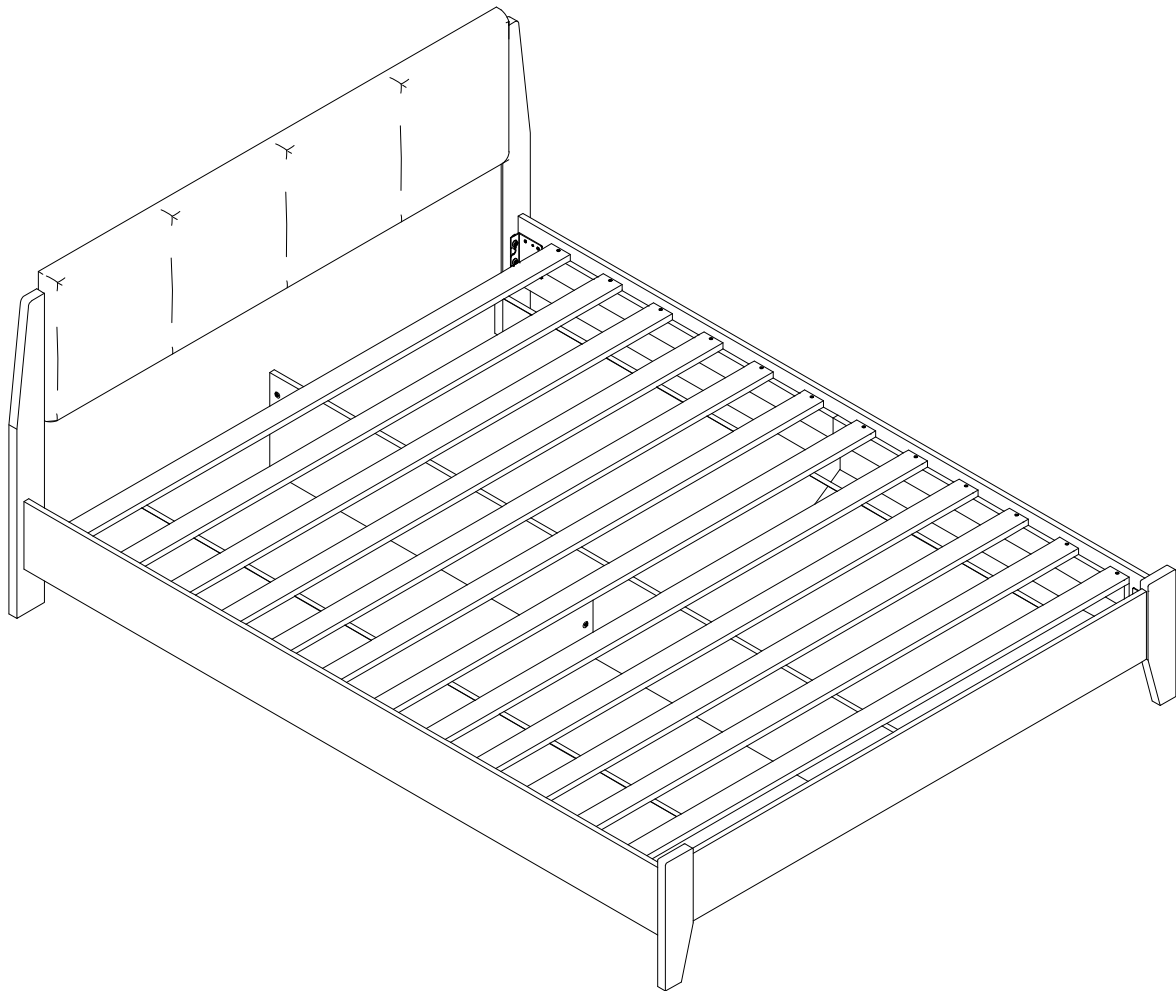

Lifely*

Product Code
NB QB1500-OK QUEEN SIZE BED-
WOODEN SLAT

Dimension (W x D x H)
2080x1600x910mm

Important

Please read through instruction carefully
Before assembly and keep for future reference.

For our full catalogue of assembly instructions,
Visit: lifely.com.au/assembly.

Important Tips and Maintenance



1.
Keep children and animals away from working area as smaller parts may cause choking if swallowed.

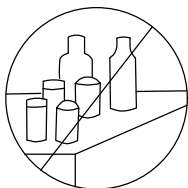

2.
Never place liquids or anything damp upon furniture as it will mark. Ensure a coaster or running is beneath.



3.
Never use ammonia based cleaning products as it will damage the finish

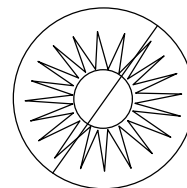

4.
To avoid fading, keep furniture out of direct sunlight.



5.
Use a soft or damp cloth (dry cloth) when wiping or cleaning surfaces.

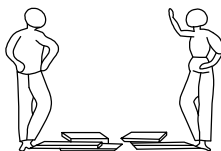

6.
Two person are required.

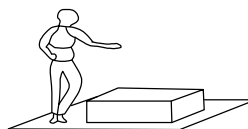

7.
Lay a soft matt down to protect the furniture piece before and during assembly.

So your relationship is strong. But is it flat-pack furniture strong? Unless you're an aerospace engineer, assembling furniture can be slightly stressful. We recommend meditating quietly, pouring yourself a herbal tea (or slightly less herbal wine) and tackling things one step at a time. If you feel a passive aggressive remark coming on, try a compliment instead. E.g. "You're so good looking".

This 22-Step assembly should take around 45 minutes with an Allen Key or 30 minutes with an electric drill. Godspeed.

Designed for everyday

Component Hardware

Please check you have all the fittings
part or tools are listed below.

No. A
Quantity:20Pcs
Dowel 6 X 30mm



No. B
Quantity:8Pcs
Bolt M6 X 16mm



No. C
Quantity:32Pcs
Screw M3.5 X 16mm



No. D
Quantity:4Pcs
Joint Bracket



No. E
Quantity:24Pcs
Screw M4 X 30mm



No. F
Quantity:12Pcs
Flange Nut



No. G
Quantity:1Pc
Spanner

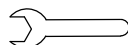

No. H
Quantity:6Sets
Cam Bolt + Cam Nut



No. I
Quantity:11Pcs
Pvc Glide



No. J
Quantity:12Pcs
PVC Air Hole



No. K
Quantity:4Pcs
Bed Bracket



Component Panel & Part List

Please check you have all the panels
are listed below.

1. Small Pillar Leg-left - - - - x1- Ctn 2/2
2. Small Pillar Leg-right - - - x1- Ctn 2/2
3. Large Pillar Leg-left - - - - x1- Ctn 2/2
4. Large Pillar Leg-right - - - x1- Ctn 2/2
5. Front Board Panel - - - - -x1- Ctn 1/2
6. Headboard Lower - - - - - x1- Ctn 1/2
7. Cushion Headboard - - - x1- Ctn 1/2
8. Centre Rail Bed - - - - - x1- Ctn 2/2
9. Left Support Bed - - - - - x1- Ctn 2/2
10. Right Support Bed - - - - -x1- Ctn 2/2
11. Left & Right Side Rail - - x2- Ctn 2/2
12. Support Bed - - - - - - - x2- Ctn 1/2

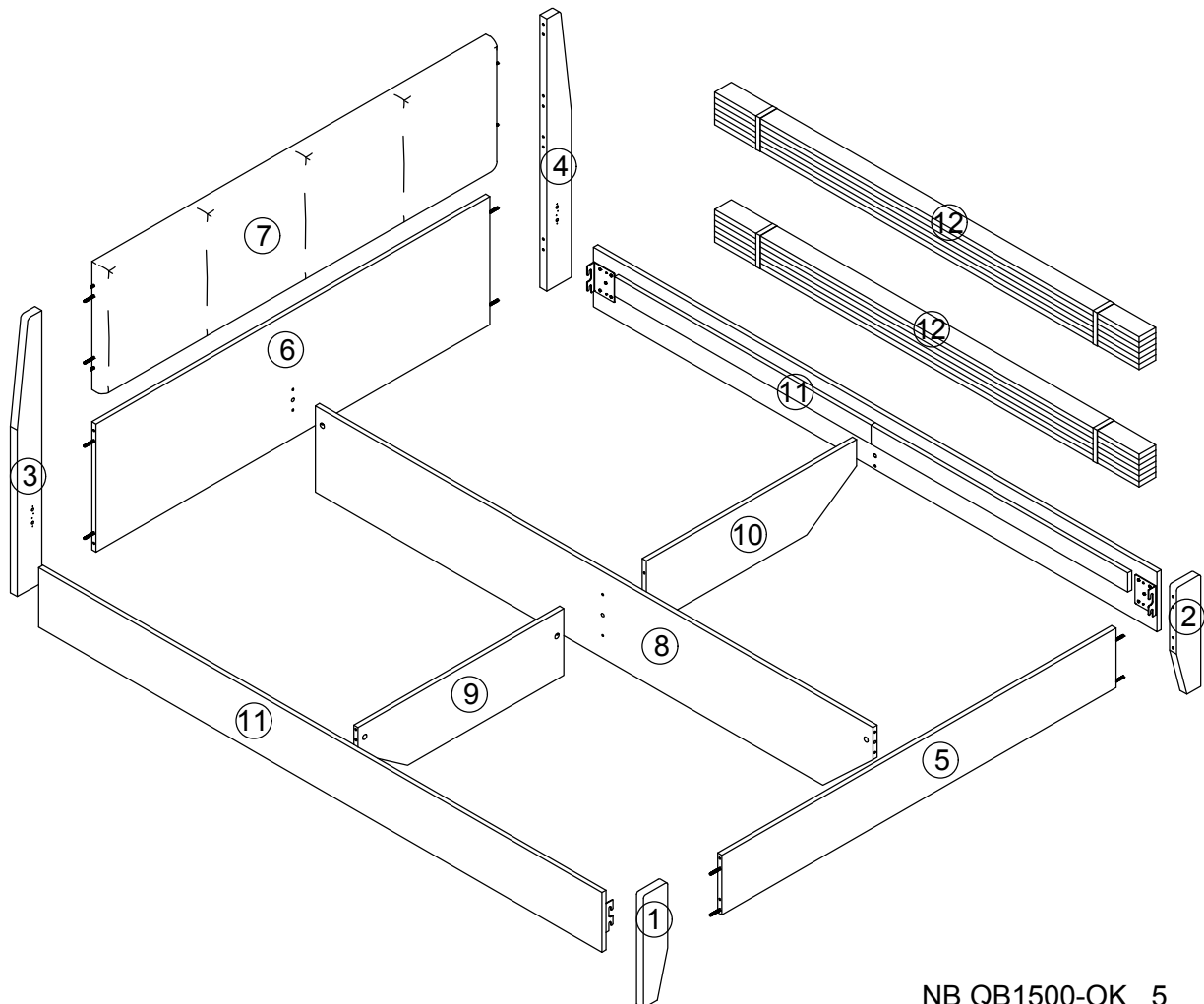

STEP 1

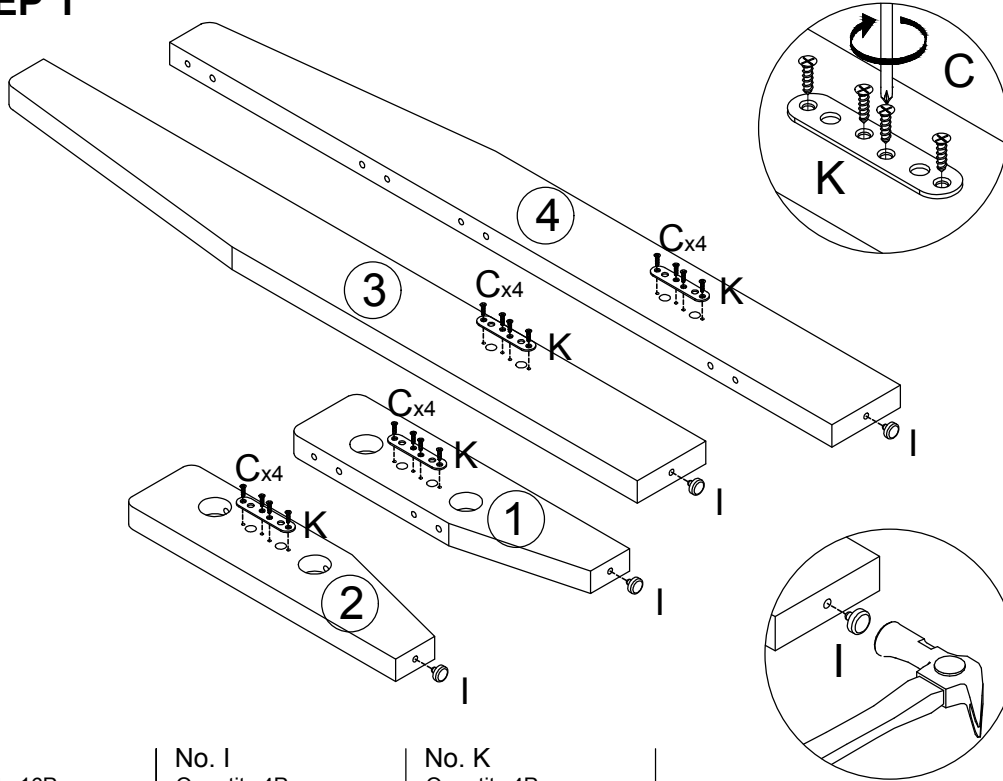

No. C
Quantity: 16Pcs
Screw M3.5 X 16mm



No. I
Quantity: 4Pcs
Pvc Glide



No. K
Quantity: 4Pcs
Bed Bracket



STEP 2

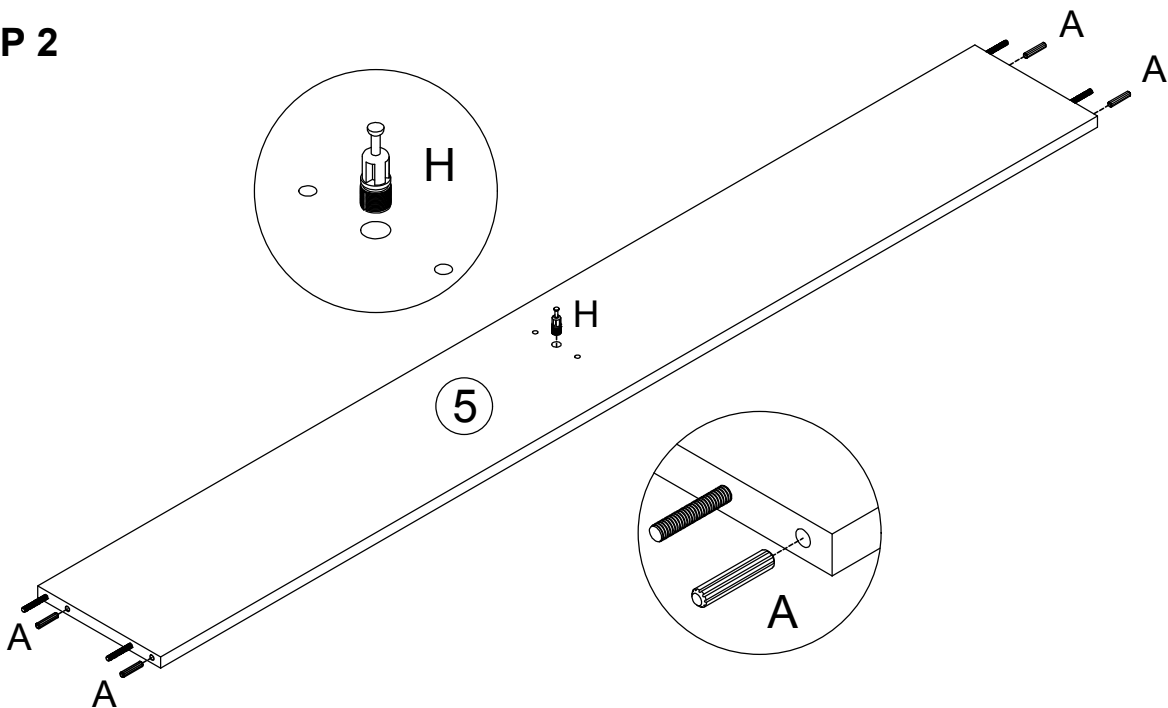

No. A
Quantity: 4Pcs
Dowel 6 X 30mm



No. H
Quantity: 1Pc
Cam Bolt



STEP 3

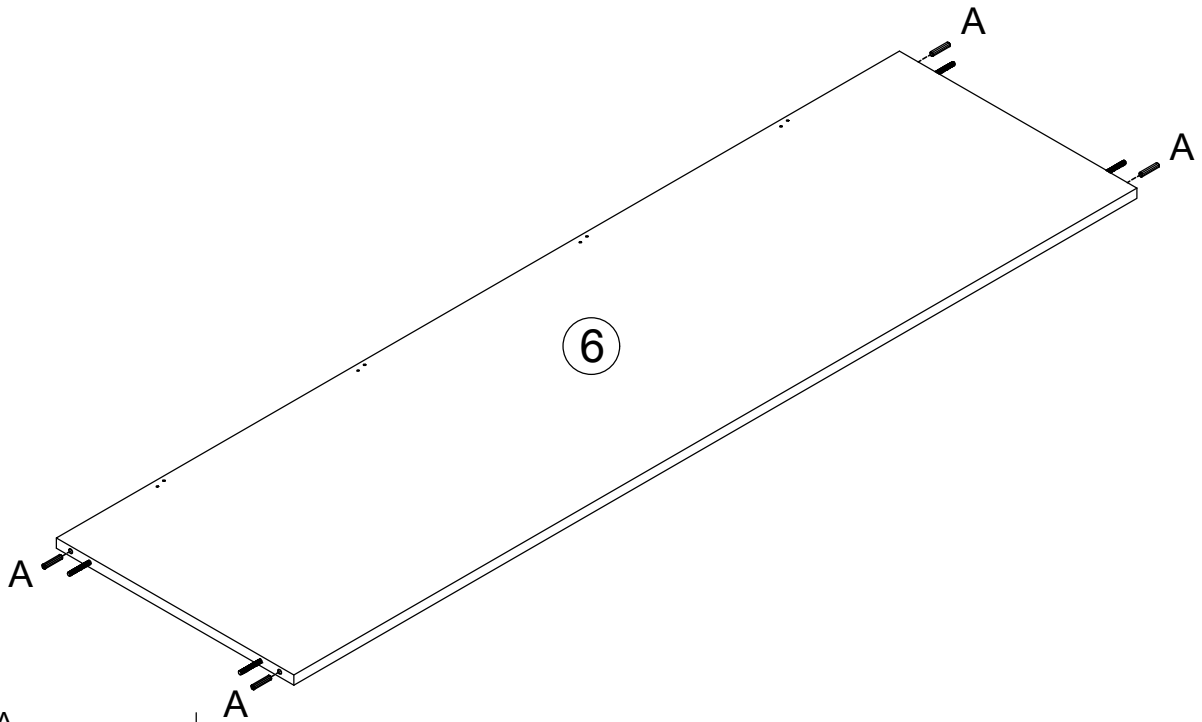

No. A
Quantity: 4Pcs
Dowel 6 X 30mm



STEP 4

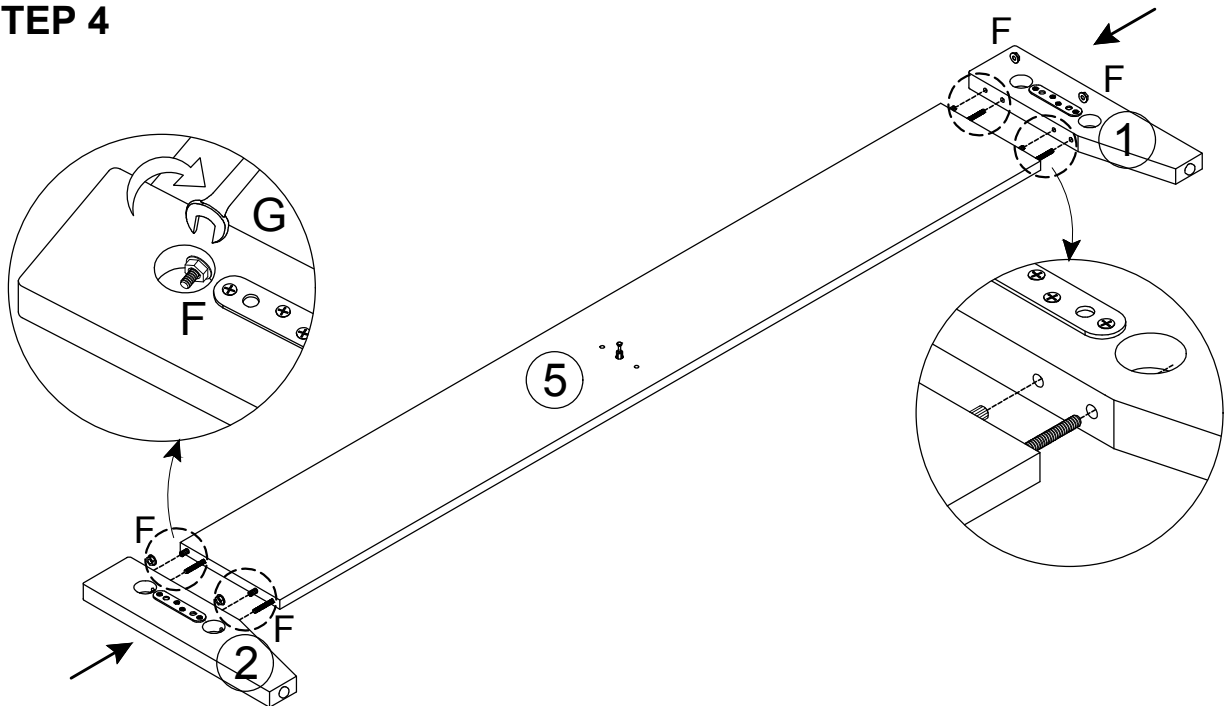

No. F
Quantity: 4Pcs
Flange Nut



No. G
Quantity: 1Pc
Spanner

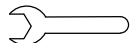

STEP 5

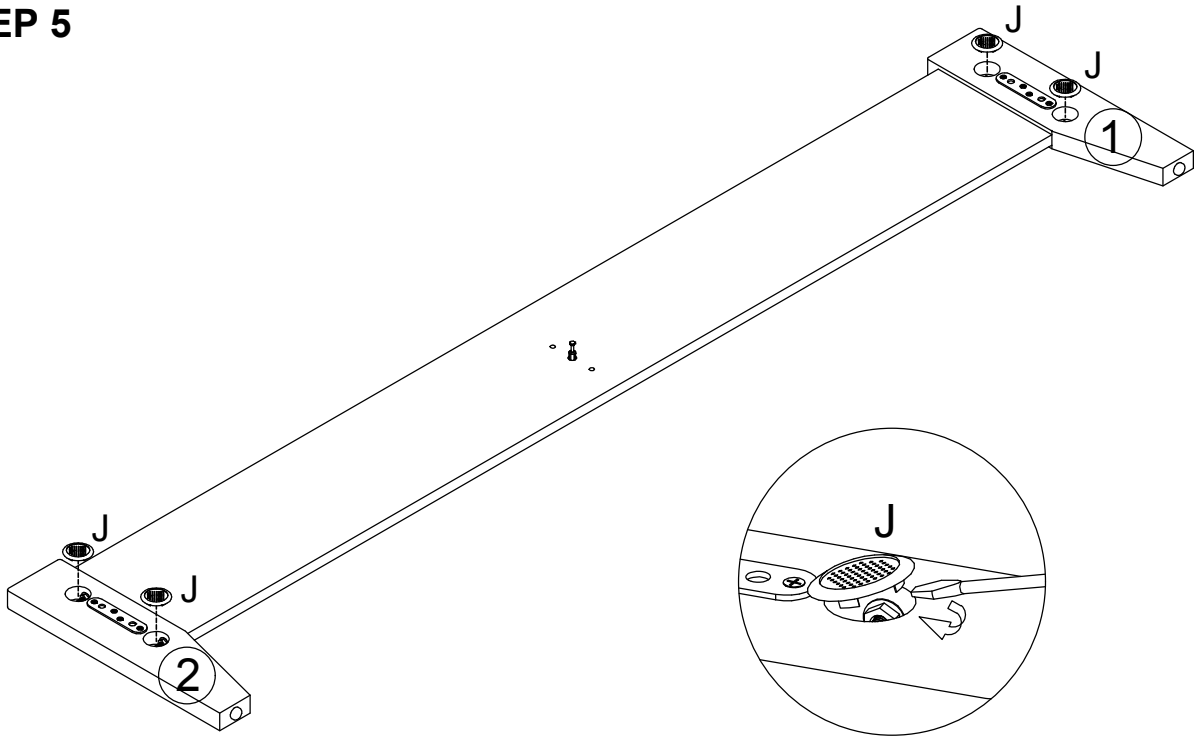

No. J
Quantity: 4Pcs
PVC Air Hole



STEP 6

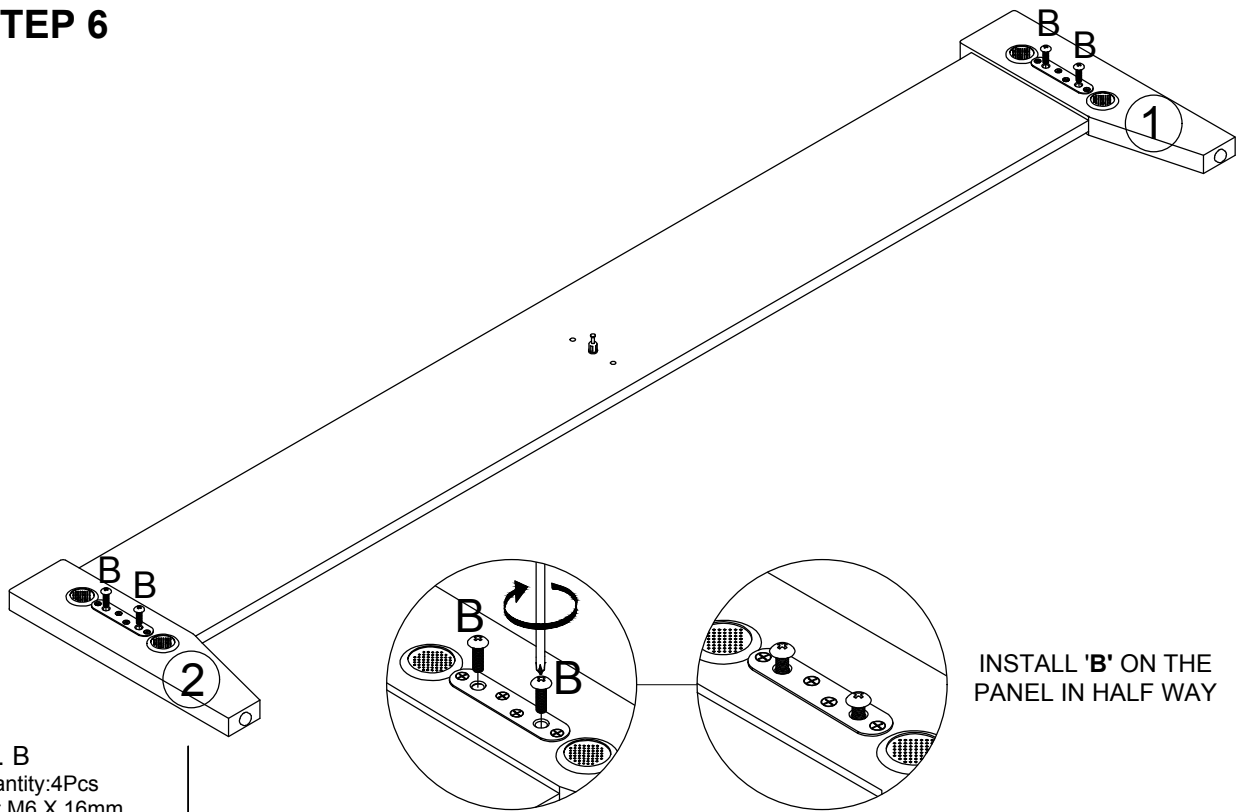

No. B
Quantity: 4Pcs
Bolt M6 X 16mm



INSTALL 'B' ON THE
PANEL IN HALF WAY

STEP 7

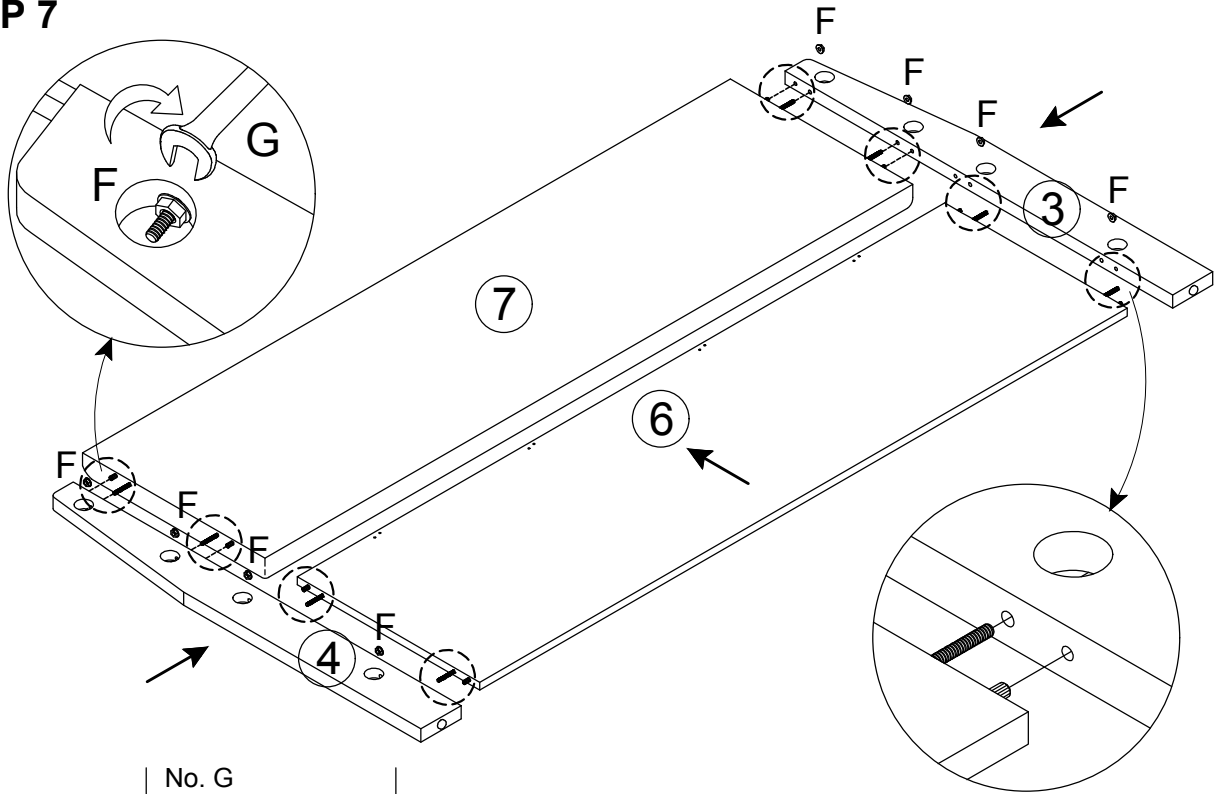

No. F
Quantity: 8Pcs
Flange Nut



No. G
Quantity: 1Pc
Spanner

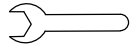

STEP 8

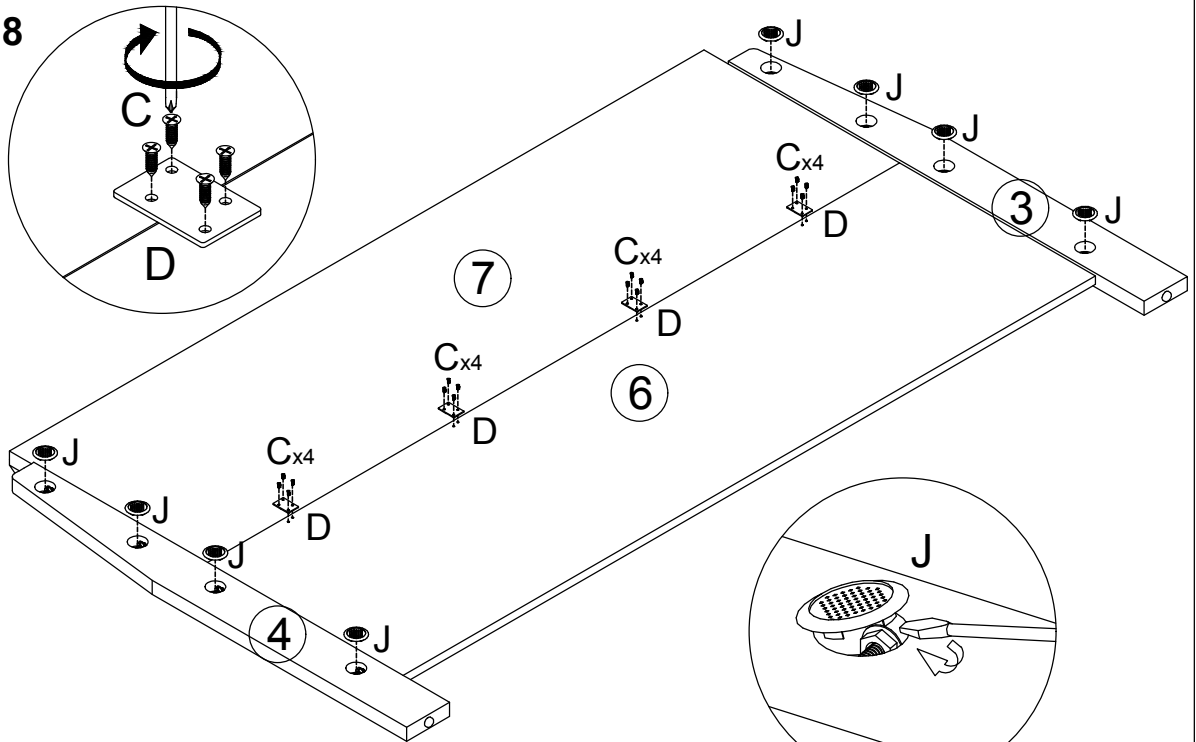

No. C
Quantity: 16Pcs
Screw M3.5 X 16mm



No. D
Quantity: 4Pcs
Joint Bracket



No. J
Quantity: 8Pcs
PVC Air Hole



STEP 9

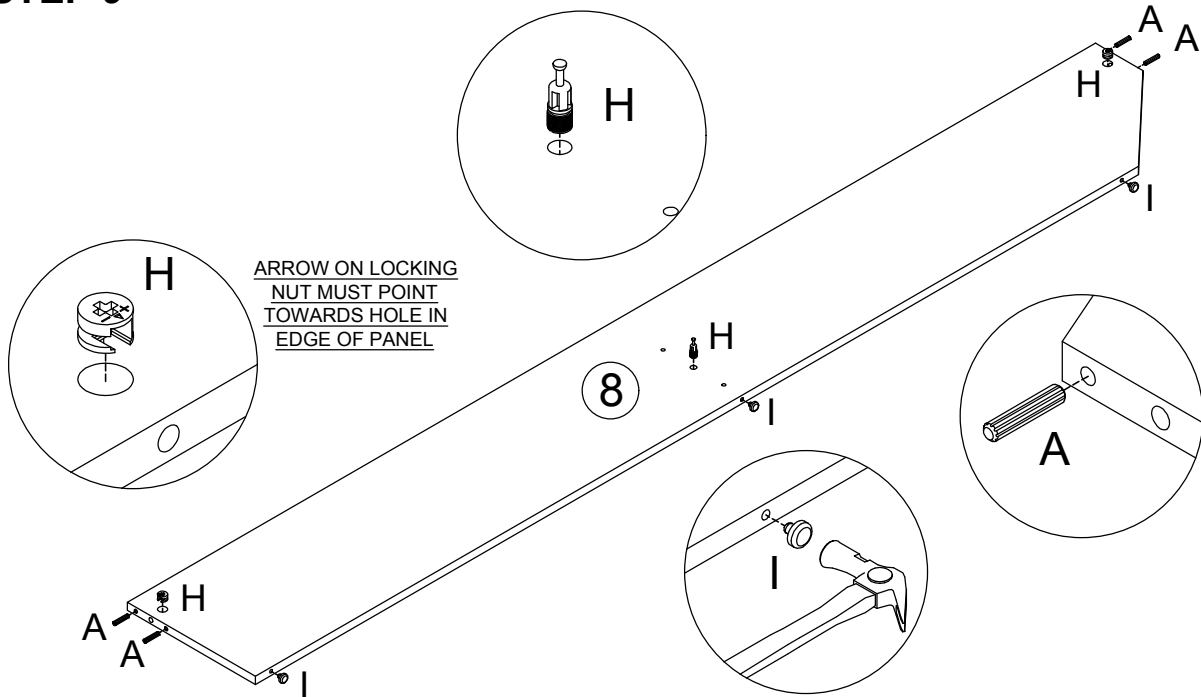

ARROW ON LOCKING
NUT MUST POINT
TOWARDS HOLE IN
EDGE OF PANEL

No. A
Quantity:4Pcs
Dowel 6 X 30mm



No. H
Quantity:2Pcs
Cam Nut



No. H
Quantity:1Pc
Cam Bolt



No. I
Quantity:3Pcs
Pvc Glide



STEP 10

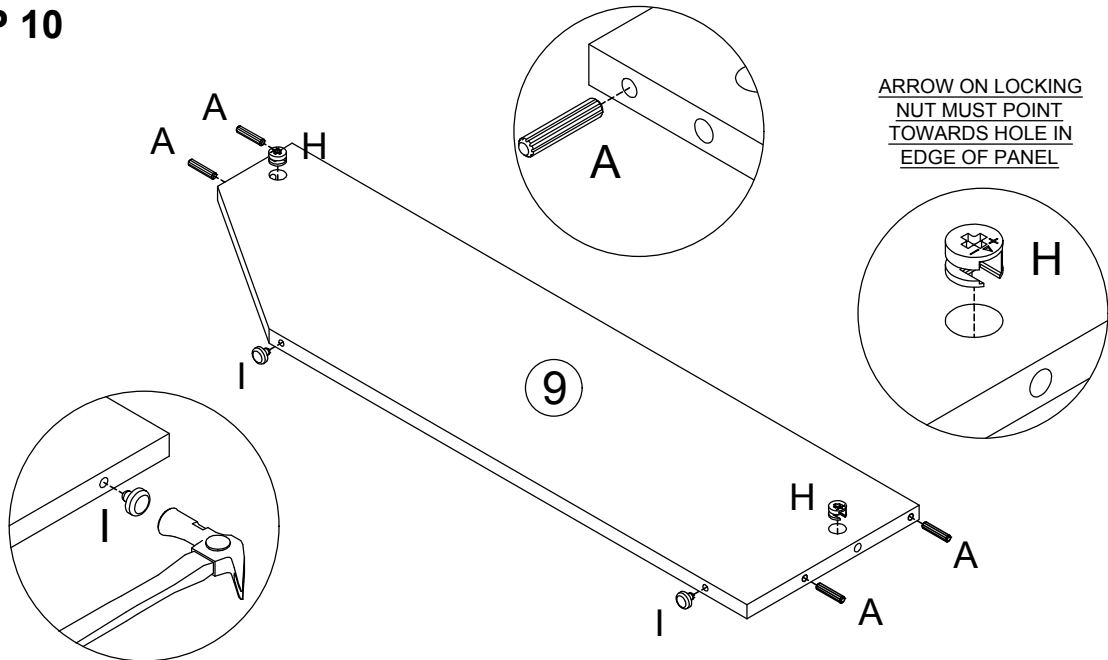

ARROW ON LOCKING
NUT MUST POINT
TOWARDS HOLE IN
EDGE OF PANEL

No. A
Quantity:4Pcs
Dowel 6 X 30mm



No. H
Quantity:2Pcs
Cam Nut



No. I
Quantity:2Pcs
Pvc Glide



STEP 11

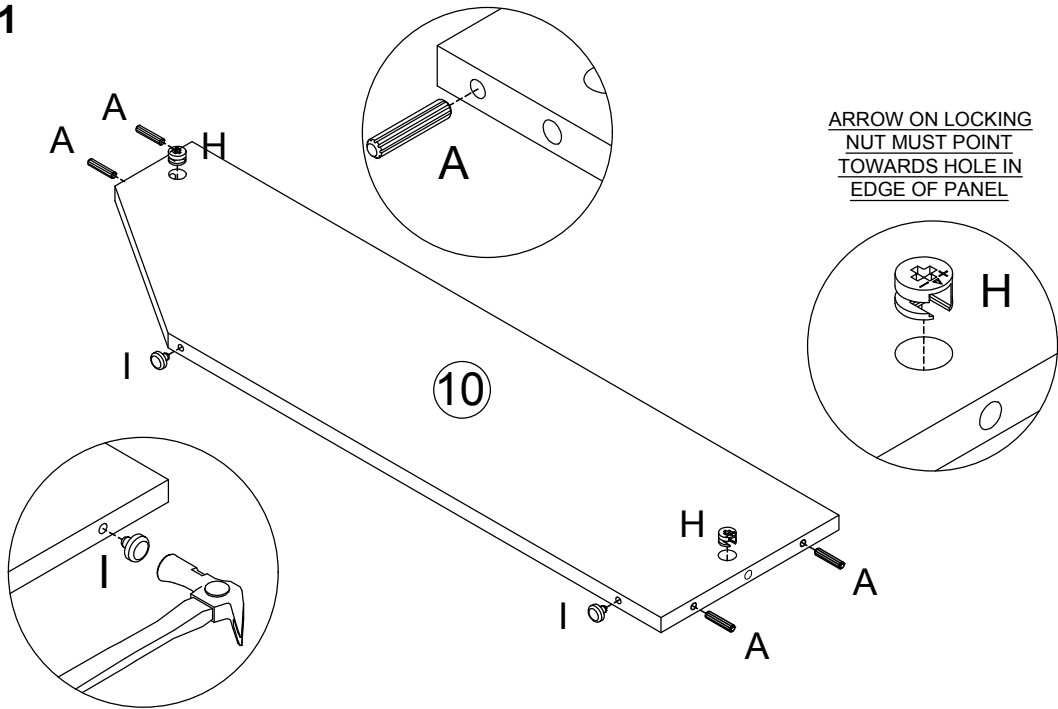

No. A
Quantity:4Pcs
Dowel 6 X 30mm



No. H
Quantity:2Pcs
Cam Nut



No. I
Quantity:2Pcs
Pvc Glide



STEP 12

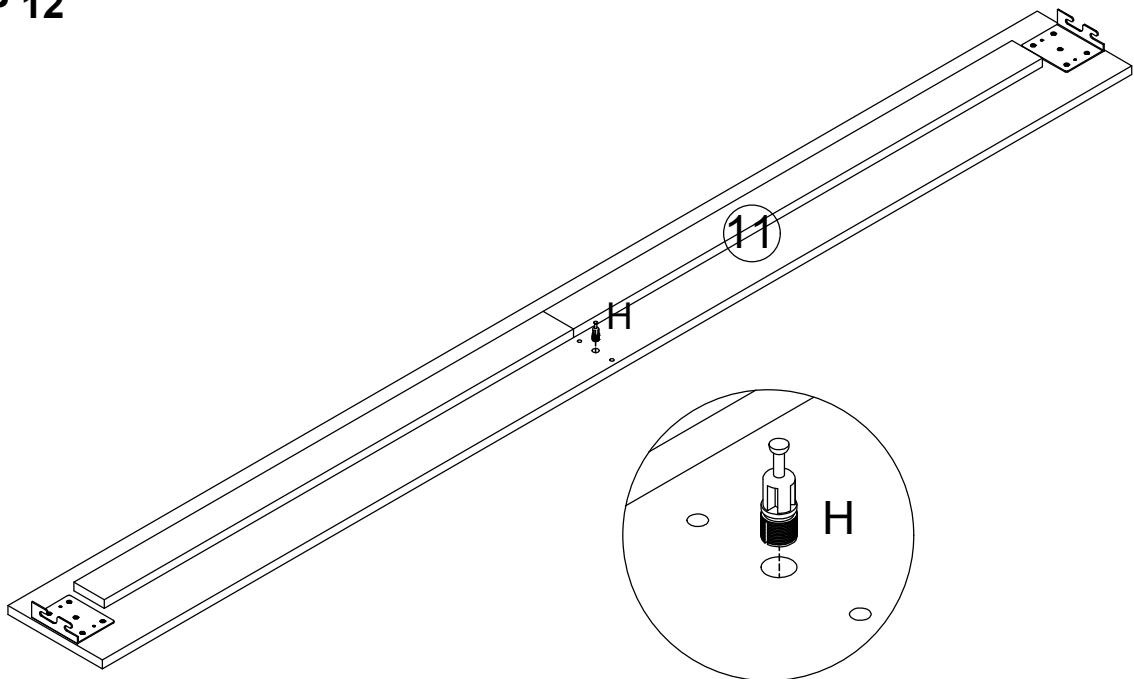

No. H
Quantity:2Pcs
Cam Bolt



2X

STEP 13

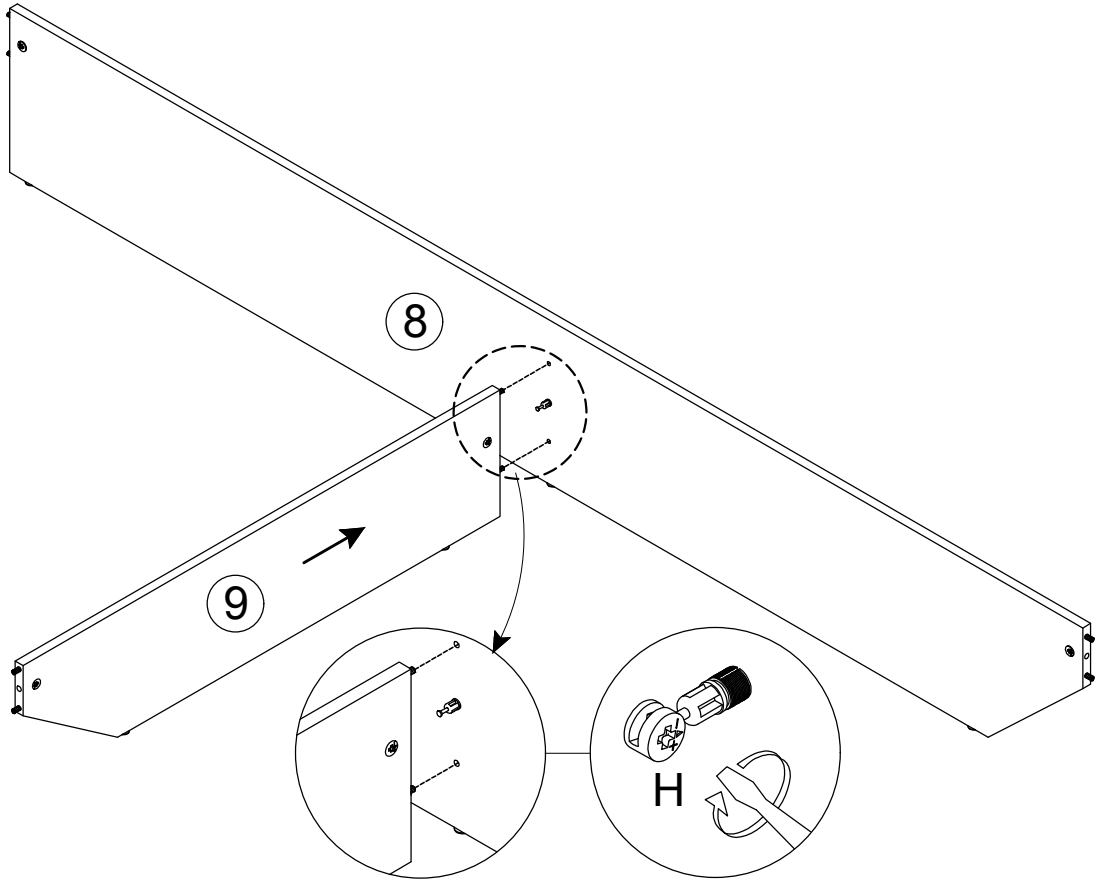

STEP 14

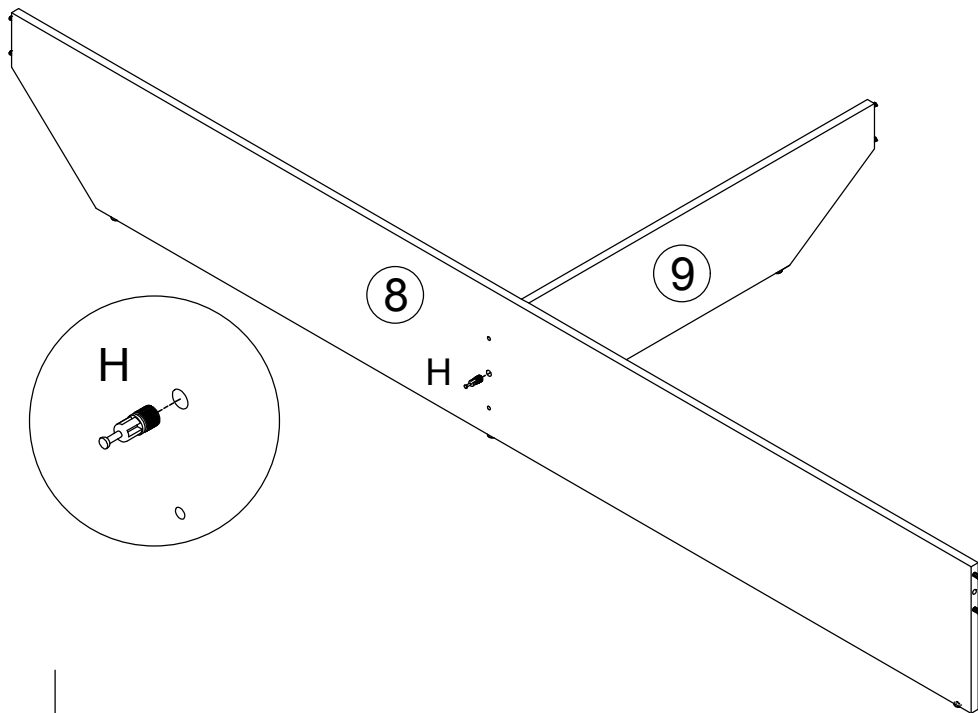

No. H
Quantity: 1Pc
Cam Bolt



STEP 15

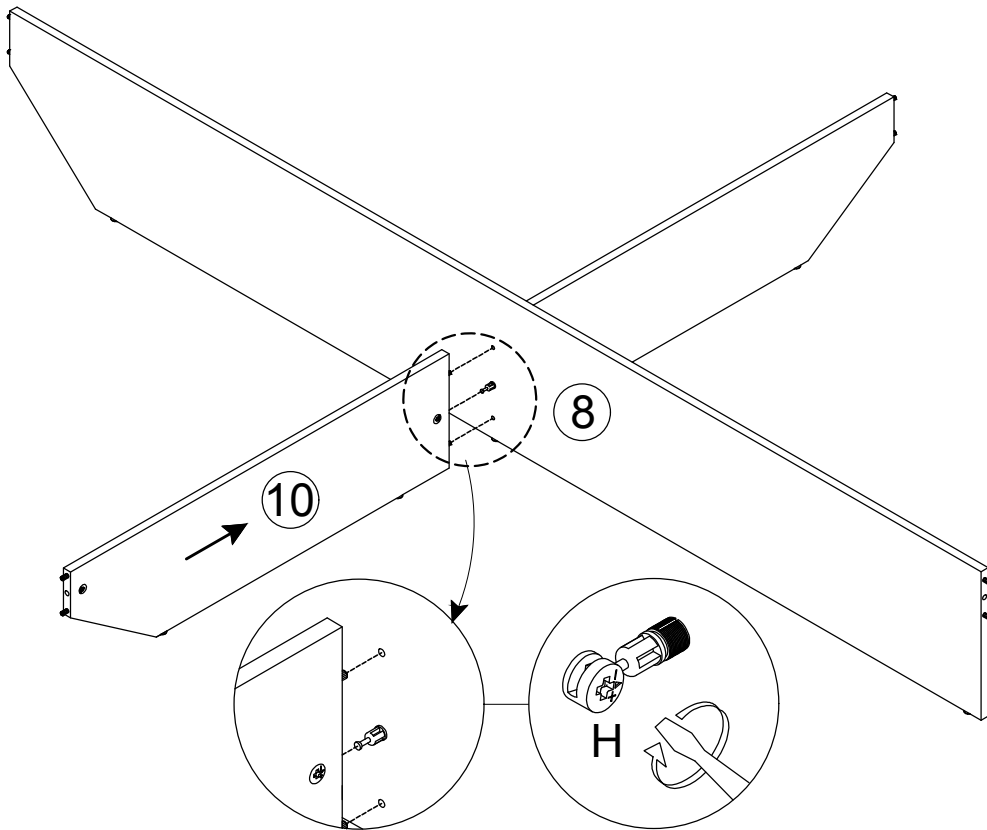

STEP 16

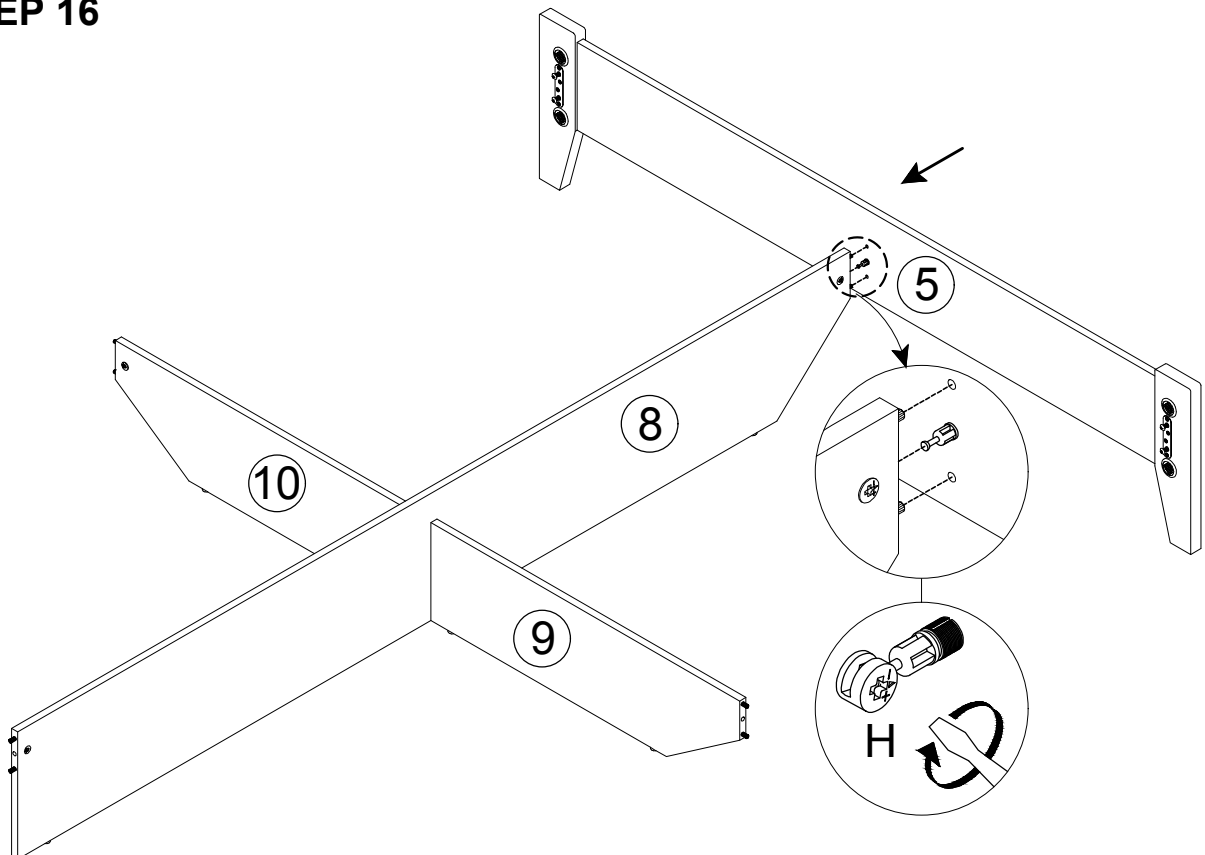

STEP 17

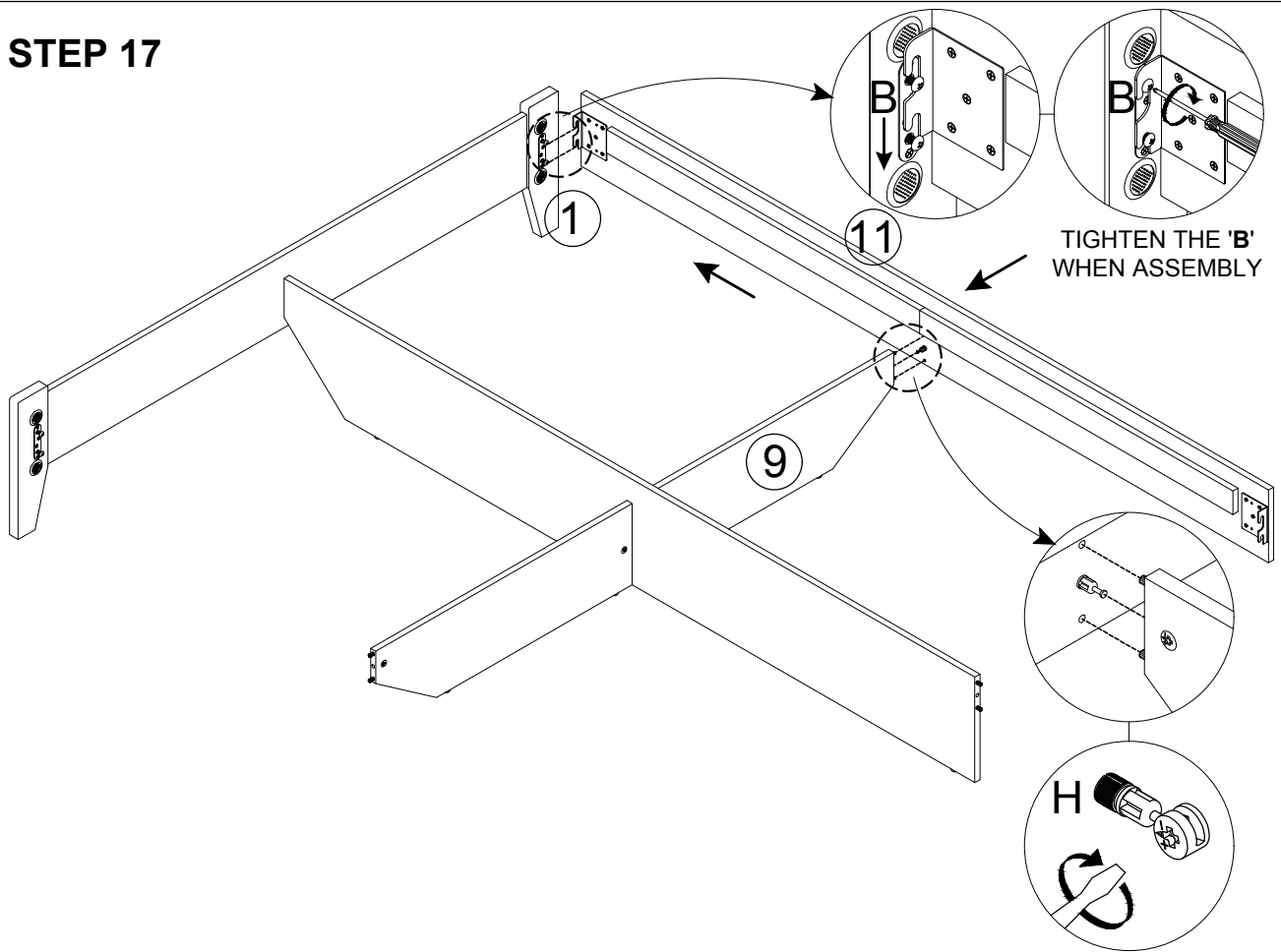

STEP 18

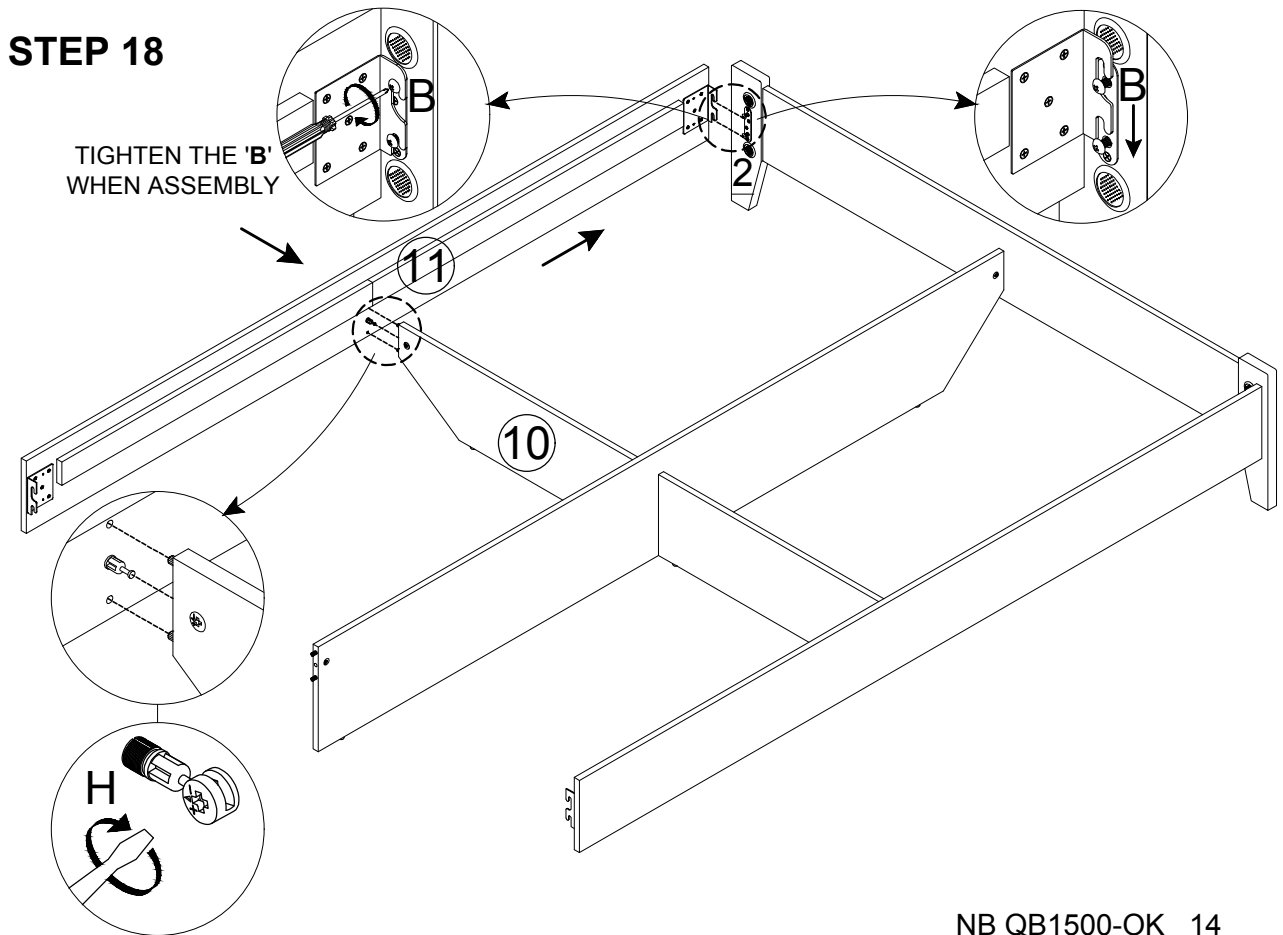

STEP 19

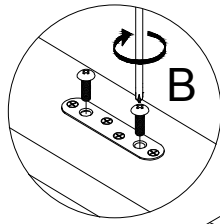
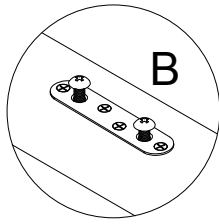

INSTALL 'B' ON THE
PANEL IN HALF WAY

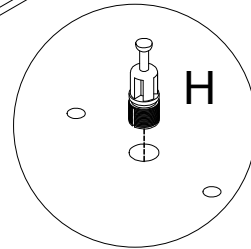
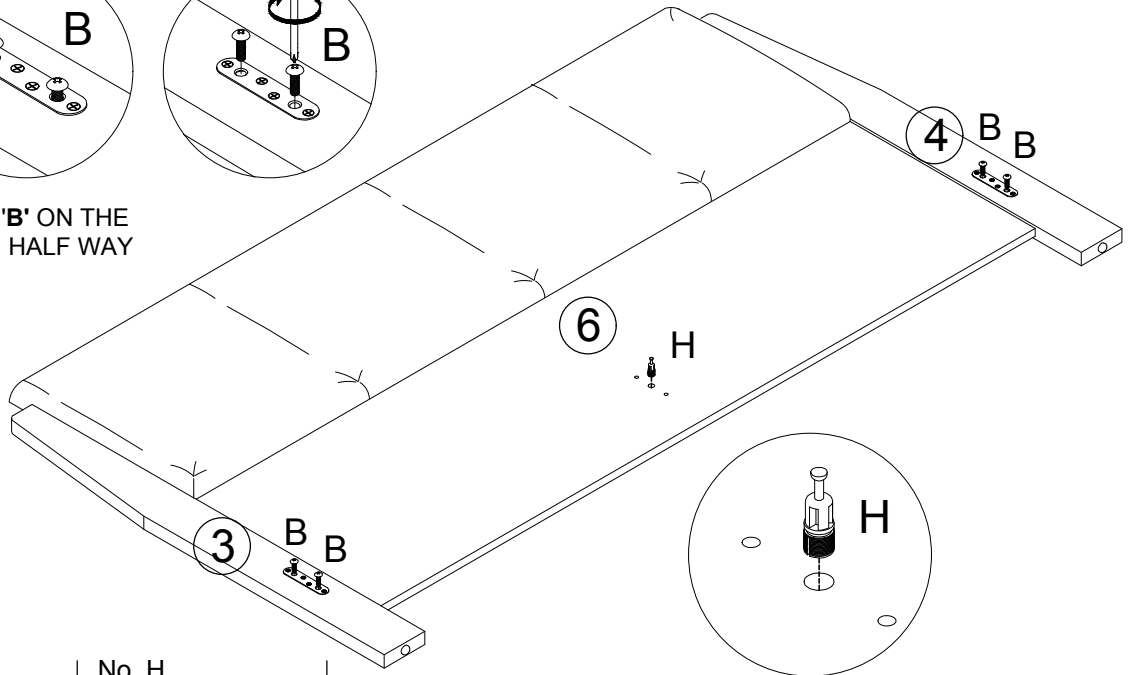

No. B
Quantity:4Pcs
Bolt M6 X 16mm



No. H
Quantity:1Pc
Cam Bolt



STEP 20

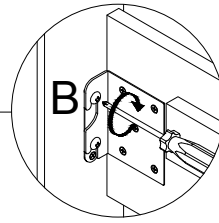
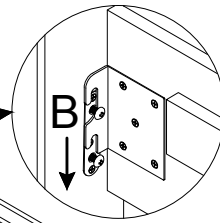
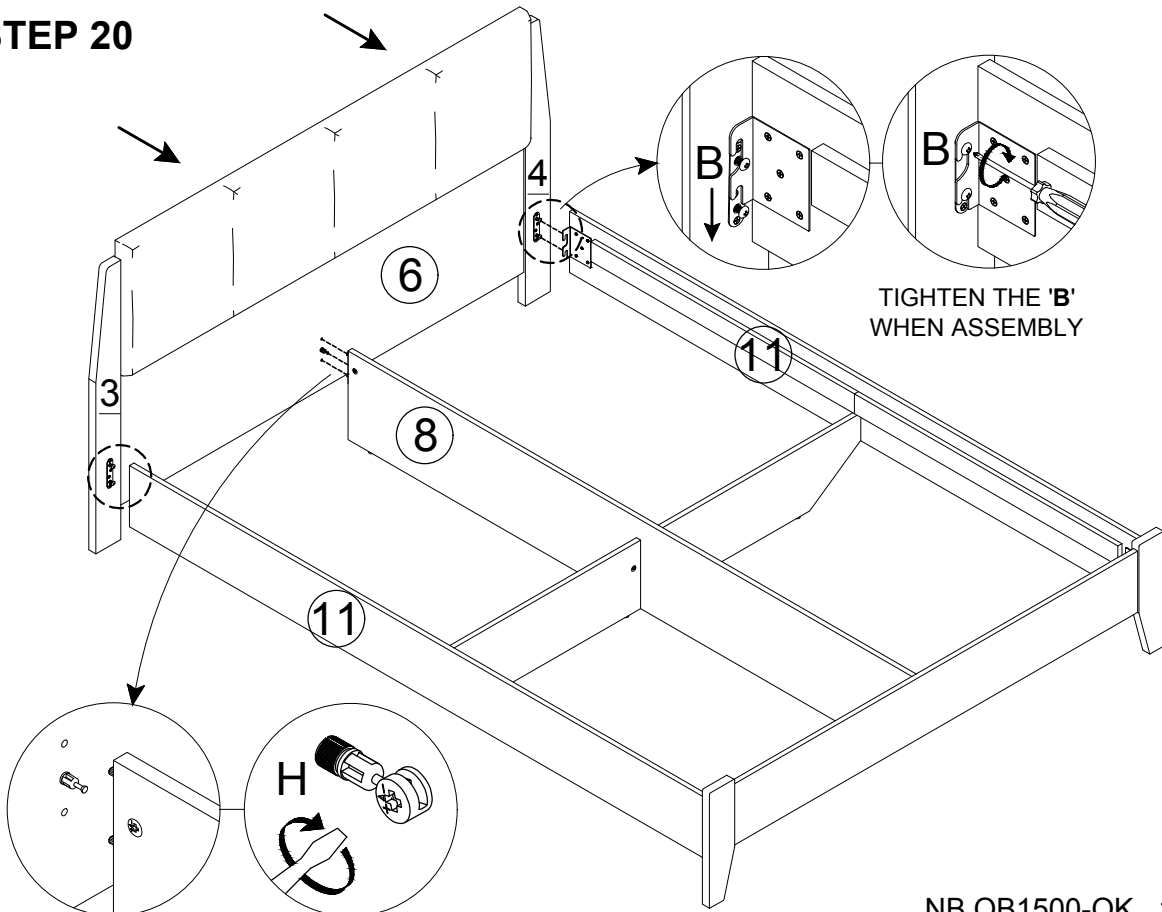

TIGHTEN THE 'B'
WHEN ASSEMBLY

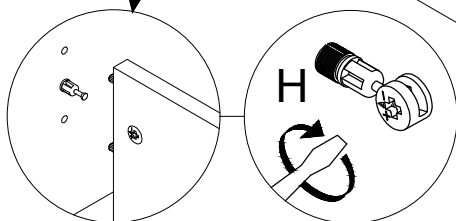

STEP 21

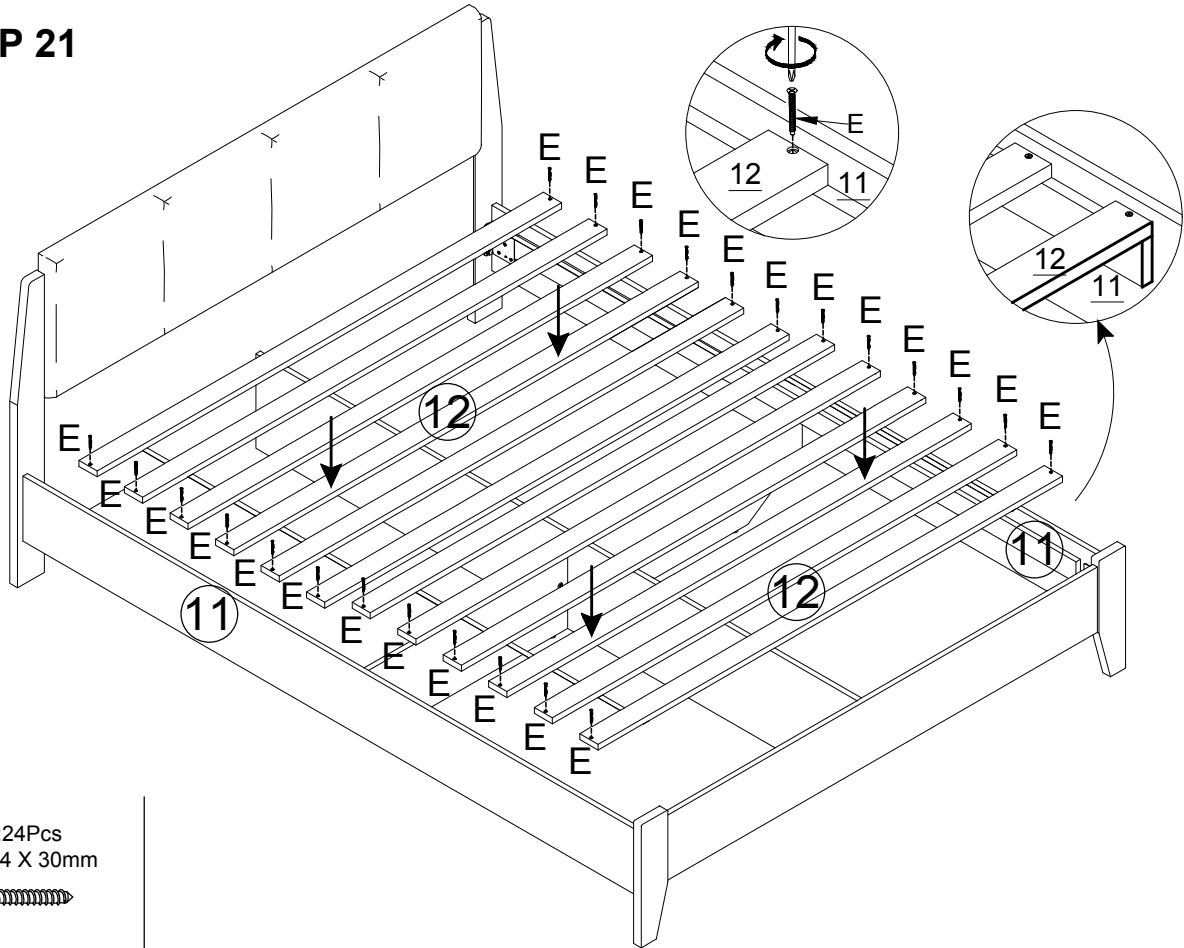

No. E
Quantity: 24 Pcs
Screw M4 X 30mm



STEP 22

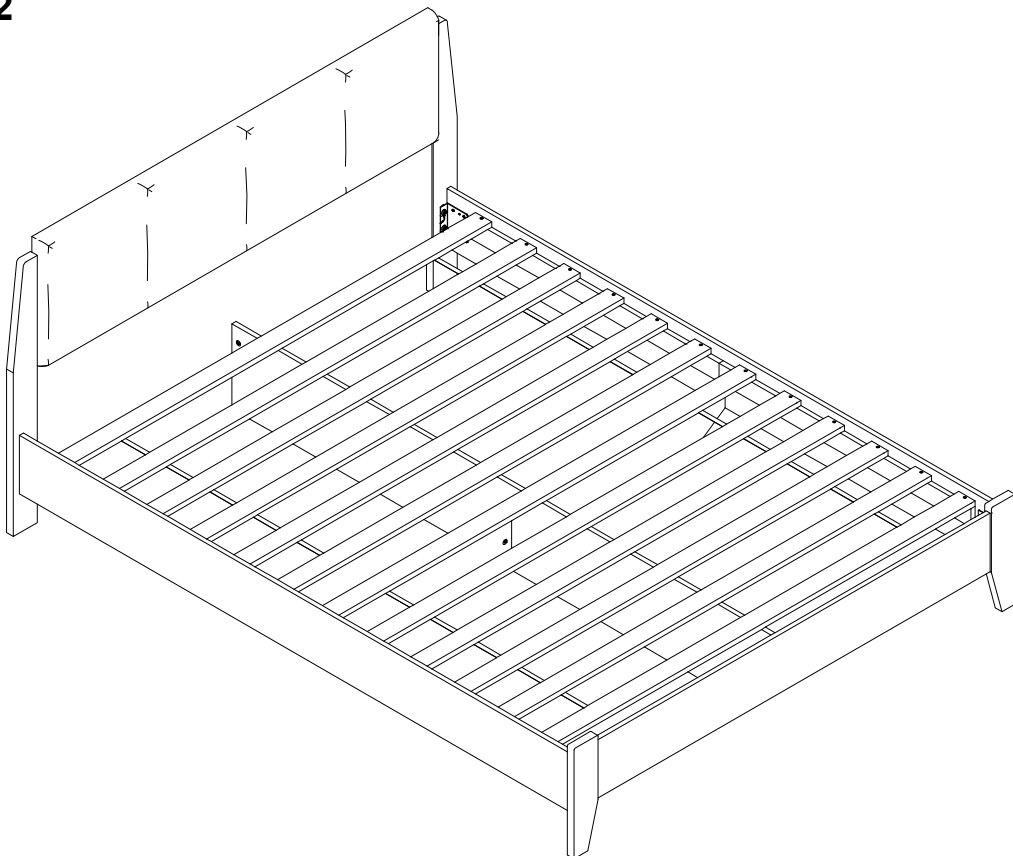

lifely.com.au

Great job. You're done!

Don't forget to share how it looks in
your space and tag us on Instagram.
[@lifelyhome](https://www.instagram.com/lifelyhome) [#homewithlifely!](https://www.instagram.com/hashtag/homewithlifely)